



BETTCHER[®] Industries, Inc.

Operating Instructions & Parts List for the Whizard Quantum[®] Drive



Manual# 109211

Issued: December 13, 2019

TMC: #839

For Assistance:

e-mail quantum@bettcher.com:

BETTCHER INDUSTRIES INC.

6801 State Route 60
Birmingham, OH 44889
U.S.A.

Phone: 440/965-4422

Phone: 800/321-8763

Fax: 440/328-4535

www.bettcher.com/quantum-motor

Information in this document is subject to change without notice.

No part of this document may be reproduced or transmitted in any form or any means, electronic or mechanical, for any purpose, without the express written permission of Bettcher Industries Inc.

Written permission to reproduce in whole or part is herewith granted to the legal owners of the Whizard Quantum® Drive with which these Operating Instructions have been supplied.

Operating Instructions in other languages are available on request. Additional copies of Operating Instructions are available by calling or writing your Regional Manager, or by contacting:

BETTCHER INDUSTRIES, INC.
6801 State Route 60
Birmingham, OH 44889
U.S.A.
Telephone: 440/965-4422
(In The U.S.A.): 800/321-8763
Fax: 440/328-4535

<http://www.bettcher.com>

The Information Provided In These Operating Instructions Is
Important To Your Health, Comfort And Safety.

For Safe And Proper Operation, Read This Entire Manual
Before Using This Equipment.



Copyright © 2019 By Bettcher Industries, Inc.
All Rights Reserved.
Original Instructions

Table of Contents

Section 1	<i>Safety</i>
Section 2	<i>Designated Use</i>
Section 3	<i>Installation</i>
Section 4	<i>Instructions for Operation</i>
Section 5	<i>Maintenance</i>
Section 6	<i>Cleaning</i>
Section 7	<i>Service Parts</i>
Section 8	<i>Contact and Document Information</i>

Section 1

Safety

CONTENTS OF THIS SECTION

Signal Word Panels	1-2
Safety Symbols	1-3
Safety Recommendations and Warnings	1-4
Safety Features	1-6
Machine Specifications	1-7
General Whizard Quantum [®] Drive Information	1-8
Measurements	1-8
Power Requirements	1-8



The information provided in these operating instructions is important to your health, comfort and safety. For safe and proper operation, read this entire manual before using this equipment.



Please read and save these instructions. Read carefully before attempting to assemble, install, operate or maintain this product. Protect yourself, others and equipment by observing all safety information. Failure to comply with instructions could result in personal injury and/or damage to the equipment. Any use in applications other than those for which the equipment was designed and built may result in equipment damage and/or serious injuries.

Retain this manual for future reference. Be thoroughly familiar with the controls and proper use of this equipment.

The manufacturer assumes no liability for any unauthorized changes in operating procedures or for unauthorized changes or modifications made to the design of the machine or any factory-installed safety equipment, whether these changes are made by the owner of this equipment, by his employees, or by service providers not previously approved by Bettcher Industries, Inc.

SIGNAL WORD PANELS



Indicates a hazardous situation that, if not avoided, will result in death or serious injury.
(The signal word **DANGER** is in white letters on a safety red background)



Indicates a hazardous situation that, if not avoided, could result in death or serious injury.
(The signal word **WARNING** is in black letters on a safety orange background)



Indicates a hazardous situation that, if not avoided, could result in minor or moderate injury.
(The signal word **CAUTION** is in black letters on a safety yellow background)



NOTICE

Indicates information considered important, but not hazard-related (e.g. messages relating to property damage).
(The signal word **NOTICE** is in italicized, white letters on a safety blue background)

The signal word definitions provided, comply with the American National Standard for Product Safety Information in Product Manuals, Instructions, and Other Collateral Materials (ANSI Z535.6-2011).

This technical manual is printed in black and white.

SAFETY SYMBOLS



The safety alert symbol indicates a potential personal injury hazard. It is not used for messages related to property damage. The safety alert symbol may be used alone or in conjunction with a signal word in a signal word panel



Danger of electrical shock



Blade hazard, keep hands clear



Read operator's manual



Protective safety gloves must be worn

Symbols are harmonized with ANSI Z535.4 and ISO 3864-2 standards. Warning symbols are presented on a safety yellow background. Mandatory action symbols are presented on a safety blue background.

This technical manual is printed in black and white.

SAFETY RECOMMENDATIONS AND WARNINGS

 **WARNING**

The manufacturer assumes no liability for any unauthorized changes in operating procedures or for unauthorized changes or modifications made to the design of the machine or any factory-installed safety equipment, whether these changes are made by the owner of this equipment, by his employees, or by service providers not previously approved by Bettcher Industries, Inc.

Use only replacement parts manufactured by Bettcher Industries, Inc. Use of substitute parts will void the warranty and may cause injury to operators and damage to equipment.

The use of parts other than those listed in the parts list for the specific model may result in an unsafe operating condition.

 **WARNING**

Sharp blades may cause cut injury!



For proper protection of hands, a protective glove should be used when operating this equipment and during the handling of blades. Metal mesh gloves are recommended for the free hand.

Keep hands away from blades.

 **WARNING**

To avoid personal injury, always disconnect the power cord before performing any adjustments, disassembly/assembly, troubleshooting or cleaning.

Always disconnect the power and remove the tool from the driveline prior to servicing.

All electrical repairs should be completed by a qualified electrician or approved service provider.

SAFETY RECOMMENDATIONS AND WARNINGS (CONTINUED)

 **WARNING**

If at any time this machine does not appear to operate normally or exhibits a marked change in performance, it should be immediately shut down, unplugged, and tagged as “UNSAFE” until such time as proper repairs are made and the machine again operates normally.

 **WARNING**

Avoid use of this machine in standing water.



SAFETY FEATURES

The Whizard Quantum[®] Drive has a handpiece hanger designed into the front of the unit for the Quantum Skinner[™]. The hanger is designed to prevent the unit from being turned on while the handpiece is in the hanger.

The hanger mechanism insures that the Quantum Skinner[™] does not fall out while hanging and requires intentional removal.

The Whizard Quantum[®] Drive will automatically turn off when the Quantum Skinner[™] is placed in the hanger.

The Whizard Quantum[®] Drive has been designed to turn off when an overload is present in a Whizard Quantum[®] driveline compatible tool. This is an indication that something is incorrect in the tool or driveline and should be inspected before restarting. To reset the unit you simply turn the switch off and then back on.

The Whizard Quantum[®] Drive has a one hand driveline insertion and removal. This reduces the potential of being cut while holding the driveline and tool while inserting the driveline into the motor drive output.

MACHINE SPECIFICATIONS

The Whizard Quantum[®] Drive is highly effective for use in the meat industry when used in conjunction with Whizard Quantum[®] driveline compatible tools. The Whizard Quantum[®] Drive has been designed with the highest possible standards for safety, ergonomics, and production and yield efficiency.

The Whizard Quantum[®] Drive Is In Conformity With The Following Directives:

- Low Voltage Directive 2006/95/EC
- Electromagnetic Compatibility Directive 2004/108/EC

Which Includes Conformity With The Following Standards:

IEC 60529	Degrees of Protection Provided by Enclosures-IP Code
BS EN 60335-1	Household & Similar Electrical Appliances - Safety
BS EN 60335-2-64	Safety of Household & Similar Electrical Appliances – Commercial Electric Kitchen Machines
BS EN 55011	Industrial, Scientific and Medical Equipment-Radio Frequency Disturbance Characteristics
BS EN 61326-1	Electrical Equipment for Measurement, Control and Laboratory Use – EMC Requirements,
BS EN 61000-3-2	EMC – Limits for Harmonic Current Emissions
BS EN 61000-3-3	EMC – Limits of Voltage Changes, Voltage Fluctuations & Flicker
BS EN 61000-4-2	EMC – Testing & Measurement – Electrostatic Discharge Immunity
BS EN 61000-4-3	EMC – Testing & Measurement – Radiated, Radio Frequency, Immunity
BS EN 61000-4-4	EMC – Testing & Measurement – Transient/Burst Immunity
BS EN 61000-4-5	EMC – Testing & Measurement – Surge Immunity
BS EN 61000-4-6	EMC – Testing & Measurement – Immunity to Conducted Disturbances Induced by Radio Frequency Fields
BS EN 61000-4-8	EMC – Testing & Measurement – Power Frequency Immunity
BS EN 61000-4-11	EMC – Testing & Measurement – Voltage Dips, Short Interruptions & Voltage Variations Immunity
UL 763	Motor Operated Commercial Food Preparing Machines
CSA C22.2 No.195	Motor Operated Food Processing Appliance-Household and Commercial Use

GENERAL WHIZARD QUANTUM[®] DRIVE INFORMATION

Measurements

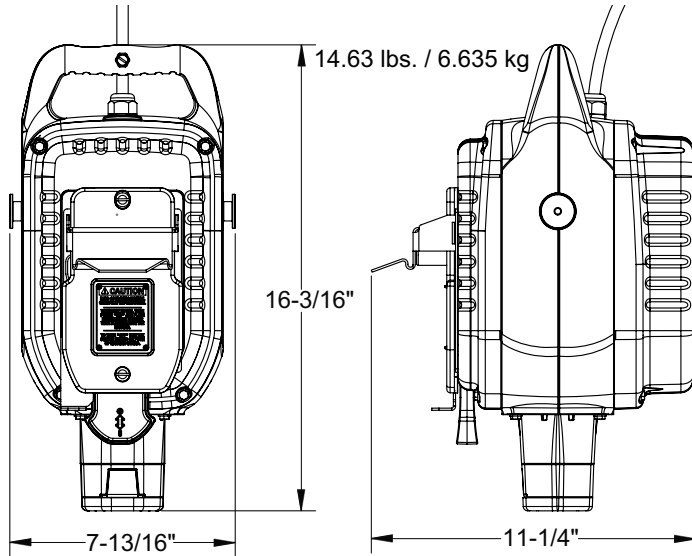

Power Requirements

WHIZARD QUANTUM[®] DRIVE "SKINNER"

115 VAC	1 PH	60 Hz
800 W	9000 / Min.	8 AMP
230 VAC	1 PH	50 Hz
800 W	9000 / Min.	8 AMP

Section 2

Designated Use

CONTENTS OF THIS SECTION

Designated Use	2-2
Recommended Operation	2-2
Function	2-2
Features	2-3

DESIGNATED USE

The Whizard Quantum[®] Drive has been specifically designed for use with Whizard Quantum[®] driveline compatible tools. Any use in application other than those for which the Whizard Quantum[®] Drive and the Whizard Quantum[®] driveline compatible tools were designed and built may result in serious injuries.

RECOMMENDED OPERATION

The Whizard Quantum[®] Drive has been designed for use with Whizard Quantum[®] driveline compatible tools.

FUNCTION

The Whizard Quantum[®] Drive will drive all current electric Whizard Quantum[®] driveline compatible tools with all the advantages, the power, and with all the performance to improve your yields and profits.

The Whizard Quantum[®] Drive rotates a flexible shaft. The flexible shaft transmits power from the drive unit to the tool by rotating a gear or pinion in the tool. Forces applied by the worker are greatly reduced and limited to guiding the tool.

FEATURES

- The Whizard Quantum[®] Drive is designed to lock the handpiece in the handpiece hanger and shuts the drive unit off when the handpiece is placed in the hanger.
- The Whizard Quantum[®] Drive will not start if the Quantum Skinner[™] is in the hanger.
- The handpiece has no metal to metal contact with the drive unit.
- The unit will shut off automatically when the Quantum Skinner[™] is placed in the hanger.



THIS PAGE INTENTIONALLY LEFT BLANK

Section 3

Unpacking and Installation

CONTENTS OF THIS SECTION

Contents	3-2
Mounting Support Yoke	3-3
Installation Dimensions	3-5
Power Source Connection	3-7



Electrical shock may occur!

Use only 3 wire ground type connector. This must be connected to a plant ground via a suitable grounded three conductor receptacle. Avoid use of this machine in standing water.



Improperly hung drive units may result in excessive operator effort & decrease in mobility. Increased fatigue & loss of efficiency may occur.



Correct installation is extremely important to achieve maximum efficiency for both the tool being used and the operator. Incorrect installation may possibly hamper the operator's movements and cause undue wear or damage to the equipment.

CONTENTS

Please check when unpacking and advise your local Bettcher Industries representative if delivery is incomplete.

The shipping carton should contain the Whizard Quantum[®] Drive, Support Yoke, and the Operating Instructions and Parts List.

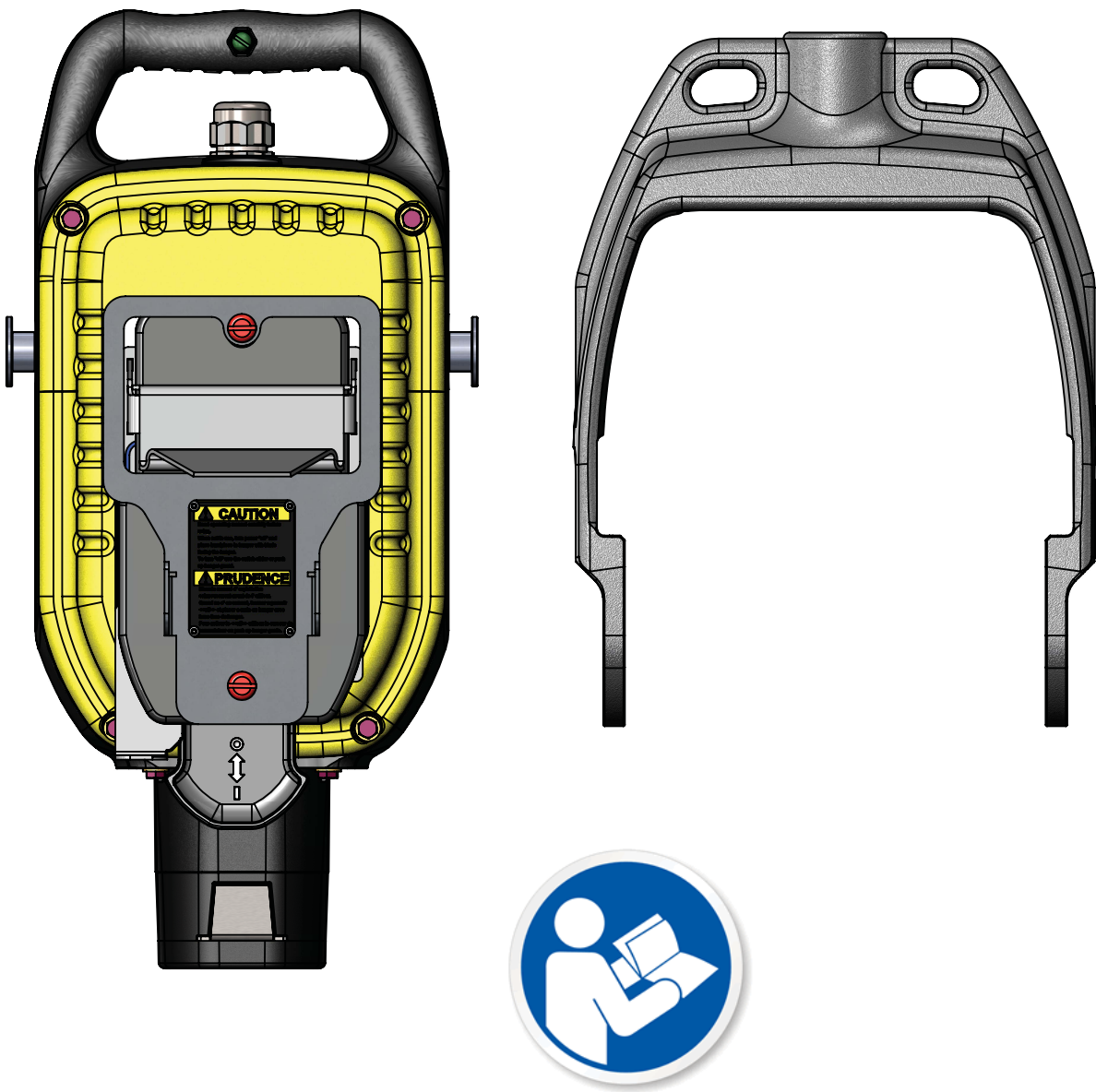

MOUNTING SUPPORT YOKE

 **WARNING**

It is strongly recommended that a safety cable or chain be installed through the support yoke and around a fixed overhead structure.

 **CAUTION**

Improperly hung drive units may result in excessive operator effort & decrease in mobility. Increased fatigue & loss of efficiency may occur.

NOTICE

Correct installation is extremely important to achieve maximum efficiency for both the tool being used and the operator. Incorrect installation may possibly hamper the operator's movements and cause undue wear or damage to the equipment.

MOUNTING SUPPORT YOKE (CONTINUED)

Correct installation is extremely important to achieve maximum efficiency for both the Whizard Quantum[®] Drive and the operator. Incorrect installation may possibly hamper the operator's movements and cause undue wear or damage to the Whizard Quantum[®] Driveline.



It is strongly recommended that a safety cable or chain be installed through the support yoke and around a fixed overhead structure.

A (3/4") 19mm diameter pipe should be fastened to an overhead beam with the pipe centerline (12 inches) 30.5cm to the right of the operator's shoulder for a right-handed operator or (12 inches) 30.5cm to the left of the operator's shoulder if the operator is left-handed.

The drive unit support yoke should be rigidly mounted and parallel to the work station.



INSTALLATION DIMENSIONS

In order to maintain correct curvature of the driveline, it is extremely important to follow installation dimensions. Dimensions for proper Whizard Quantum[®] Drive installation are based on the distance offset from the shoulder (**A**), the distance out from the table top (**B**), and the height above the work surface (**C**).

A	Distance Offset From Shoulder
B	Distance Out From Table Top
C	Height Above Cutting Level

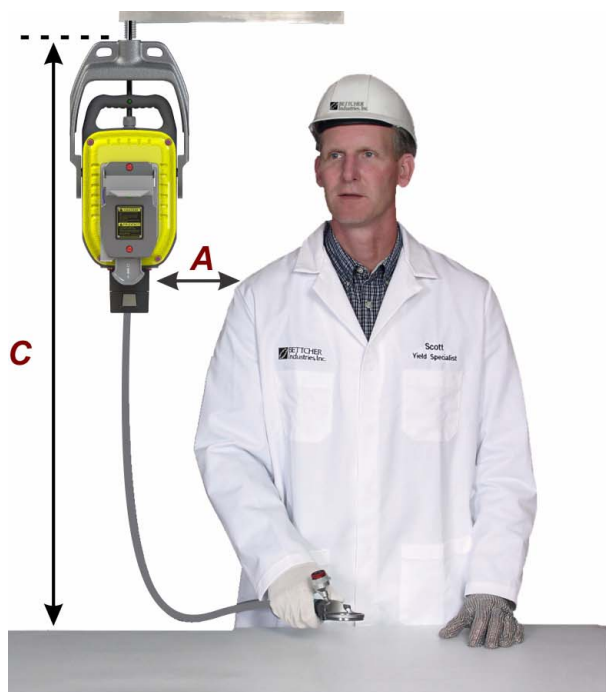

Whizard Quantum[®] Driveline Size	A	B	C
Short - 48	12"	12"	49 1/2"
Long - 60	12"	15"	63 1/2"
Extra Long - 84	12"	15"*	63 1/2"

* Application Dependent: Distances can be adjusted as needed.

ATTACHING BETTCHER QUANTUM[®] DRIVE TO SUPPORT YOKE

 **WARNING**

To avoid personal injury, always disconnect the power cord before performing any adjustments, disassembly/assembly, troubleshooting or cleaning.



Always remove the driveline and tool from the drive unit prior to mounting or removing the drive unit.

Hold the Bettcher Quantum[®] Drive so the controller side is pointing down and parallel to the floor. Lift the drive unit up and through the support yoke opening, aligning the flats on the pivots of the drive unit with the slots in the support yoke inserts. Lower the drive unit into the inserts and carefully allow the drive unit to slowly rotate to the vertical position. The drive unit should swivel freely in the support yoke. The hanger should appear on the right side when facing the front of the unit.

To **REMOVE** the Bettcher Quantum[®] Drive from the support yoke, rotate the drive unit so the controller side is pointing down and parallel to the floor, then lift up and out of the support yoke.

The Bettcher Quantum[®] Drive is intended to be permanently installed and only removed for maintenance purposes.

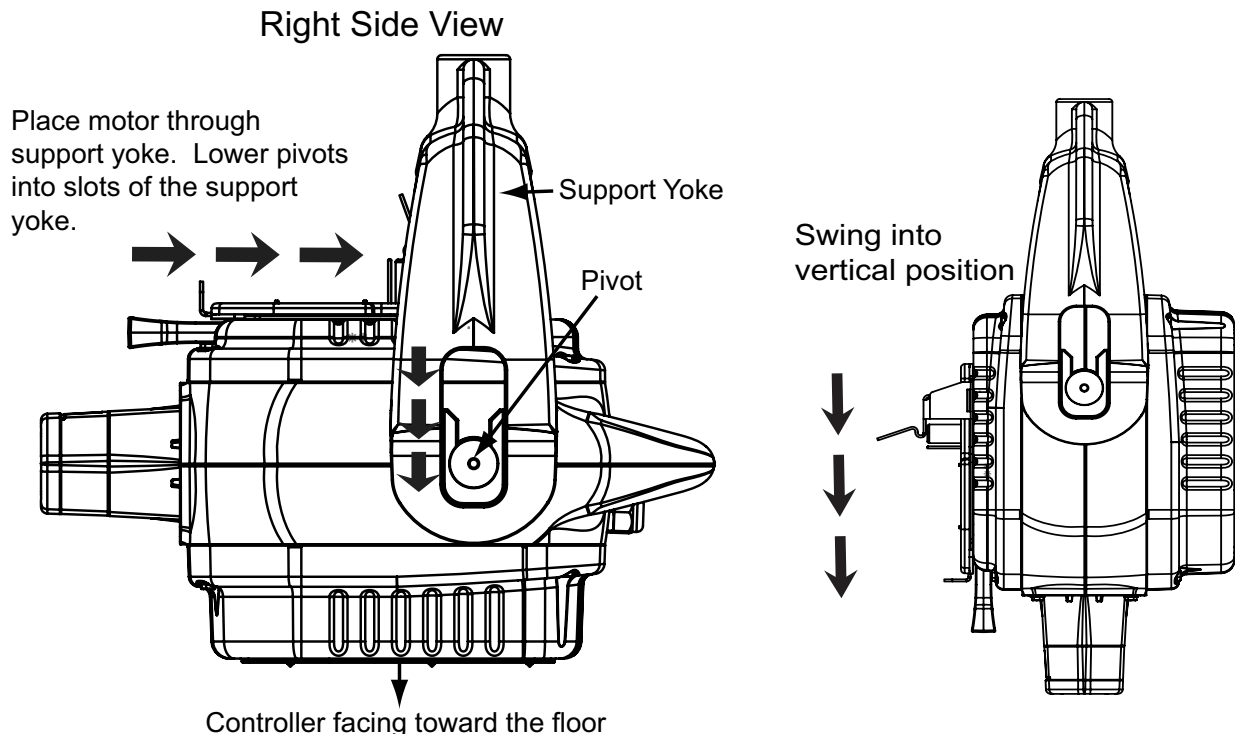

POWER SOURCE CONNECTION



Electrical shock may occur!



Use only 3 wire ground type connector. This must be connected to a plant ground via a suitable grounded three conductor receptacle. Avoid use of this machine in standing water.

Connect the Whizard Quantum[®] Drive power cord to the prescribed voltage on the drive unit nameplate. The drive unit must be connected to a ground. Use only approved type connector.

Connect the motor power cord to the prescribed voltage using a three (3) prong grounded plug (Line Power, Neutral, and Ground).

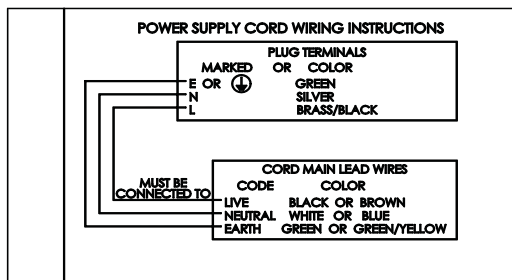
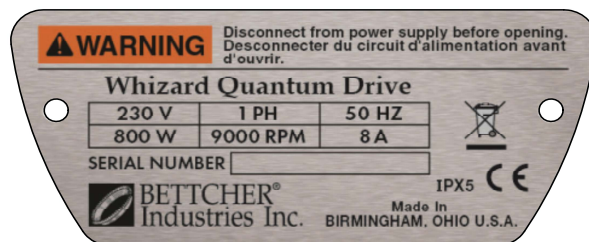
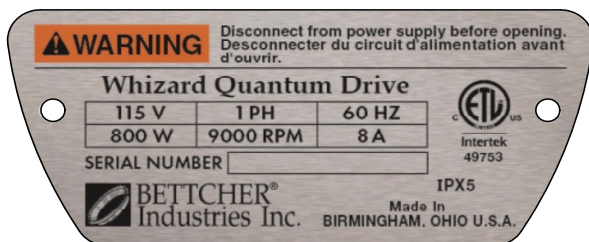

THIS PAGE INTENTIONALLY LEFT BLANK

Section 4

Instructions for Operation

CONTENTS OF THIS SECTION

Whizard Quantum [®] Driveline Assembly	4-2
Install Whizard Quantum [®] Driveline to disconnect body	4-2
Remove Whizard Quantum [®] Driveline from disconnect body	4-2
Attaching Tool to Whizard Quantum [®] Driveline	4-3
Non-Disconnect Models	4-3
Disconnect Models	4-4
Storing Quantum [®] Handheld Skinner in Hanger	4-5
Removing Quantum [®] Handheld Skinner from Hanger	4-6
Turning ON the Whizard Quantum [®] Drive	4-7
Turning OFF the Whizard Quantum [®] Drive	4-7

WHIZARD QUANTUM® DRIVELINE ASSEMBLY

Install Whizard Quantum® Driveline to disconnect body

Insert proper end of Whizard Quantum® Driveline into disconnect body. The driveline will latch in place when fully inserted into disconnect body.

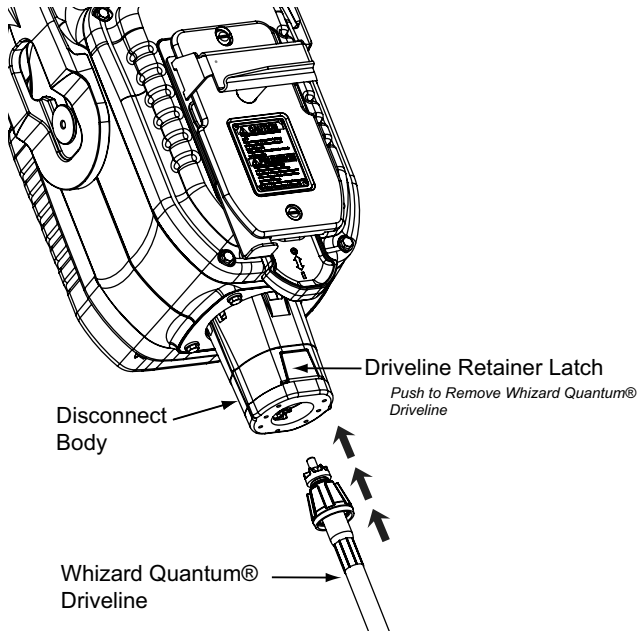

Remove Whizard Quantum® Driveline from disconnect body

Hold Whizard Quantum® Driveline around the top exposed portion, just below the disconnect body. Push driveline retainer latch inward and pull driveline down and out of disconnect body.

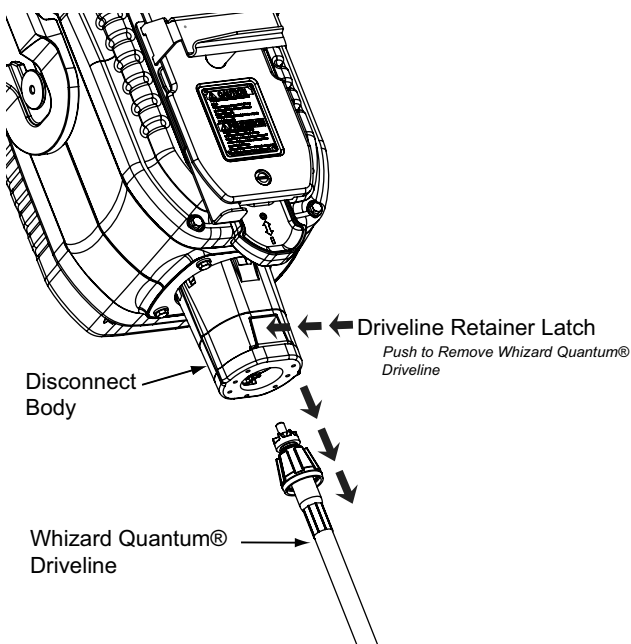

ATTACHING TOOL TO WHIZARD QUANTUM[®] DRIVELINE

Non-Disconnect Models

1. Hold tool in the hand you will use in operation.
2. With opposite hand, grasp driveline and push it through handle retaining knob.
3. Push driveline until both detents on latch collar are inserted. Two clicks (2) will be heard.

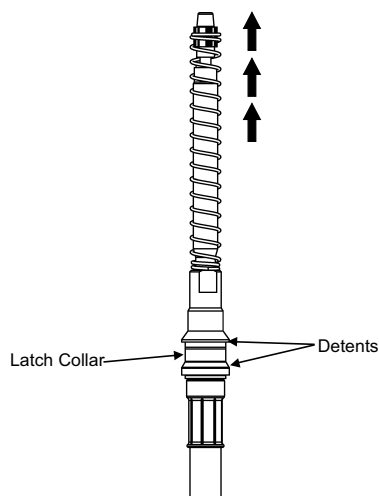
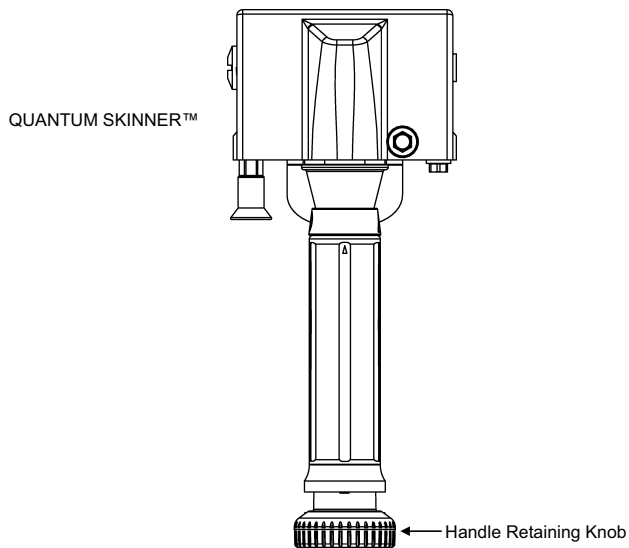

ATTACHING TOOL TO WHIZARD QUANTUM[®] DRIVELINE (CONTINUED)

Disconnect Models

1. Hold tool in the hand you will use in operation.
2. With opposite hand, grasp driveline and push it through handle retaining knob.
3. Push driveline until detent on latch collar is inserted. One click (1) will be heard.
4. Disconnect lever will rotate freely around handle.
5. Align disconnect lever in notched-out area of handle. Slightly open fingers on the hand holding the trimmer. Push driveline inward and hold disconnect lever down in handle groove with normal operating hand.
6. Make certain disconnect lever is seated completely flat within handle groove.
7. When disconnect lever is released, driveline should pop out of operating position and stop tool from running. The drive unit will continue to operate.

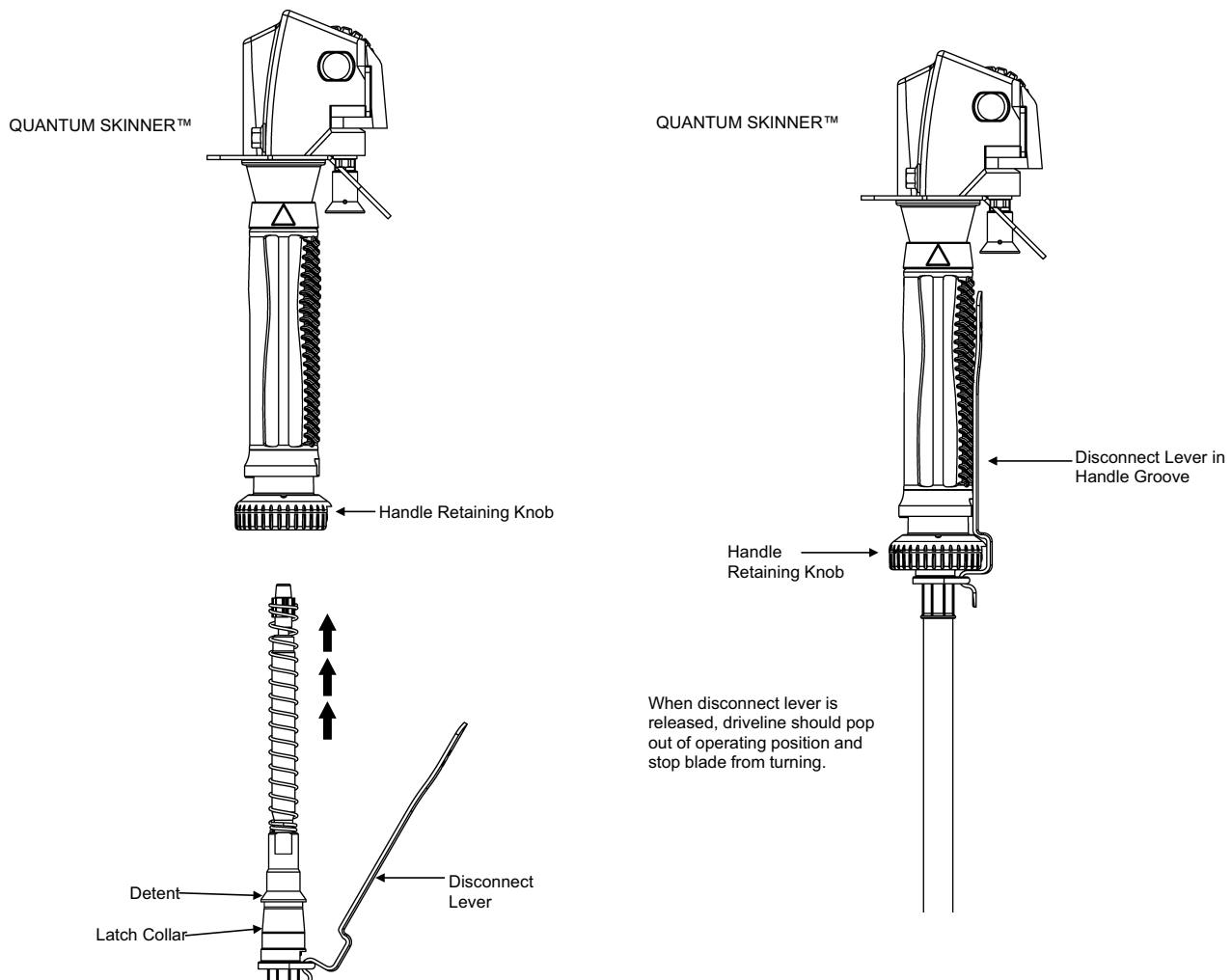

STORING QUANTUM[®] HANDHELD SKINNER IN HANGER

WARNING

Always turn off the Whizard Quantum[®] Drive and place the handpiece in the hanger bracket. Never lay the handpiece down on the workstation or let it hang free by the driveline. Never place the handpiece in the hanger while the blade is still revolving.

NOTICE

The hanger is used only for Quantum[®] Handheld Skinner.

Place QuantumSkinner[™] in hanger:

1. With your left hand, swing latch to the left and lift up handpiece bracket to full, raised position. **Note:** The latch and handpiece bracket are attached to one another.
2. Place QuantumSkinner[™] onto hanger. The hanger has two (2) legs that the tool's blade retainer will rest on. These legs will fit inside the backside of the tool frame.
3. Lower handpiece bracket down so its inside surface rests on front edge of Handheld Skinner Tool.

The QuantumSkinner[™] is now captured in the hanger. The spring loaded latch will prevent the QuantumSkinner[™] from being accidentally knocked out of the hanger.

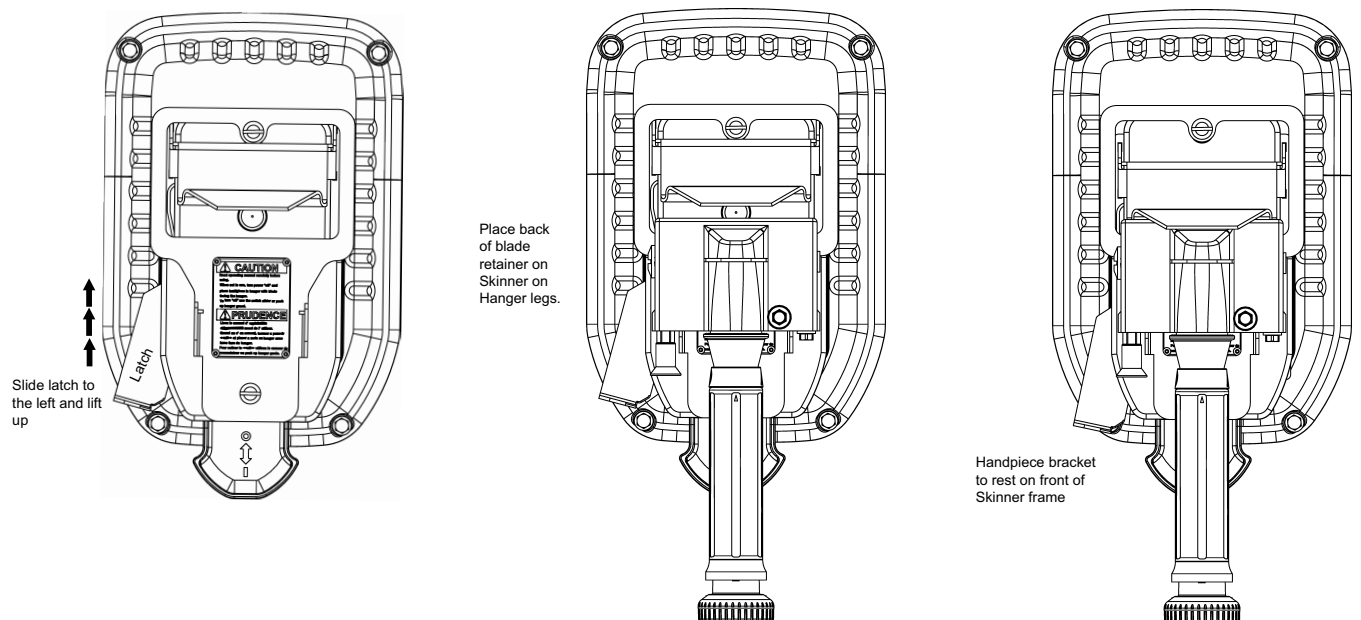

REMOVING QUANTUM[®] HANDHELD SKINNER FROM HANGER

NOTICE

The hanger is used only for Quantum[®] Handheld Skinners.

Remove QuantumSkinner[™] from hanger:

1. Firmly grasp QuantumSkinner[™] handle with your dominant hand.
2. Swing latch to the left with your opposite hand and lift handpiece bracket to its fully raised position.
3. Carefully remove skinner from hanger.

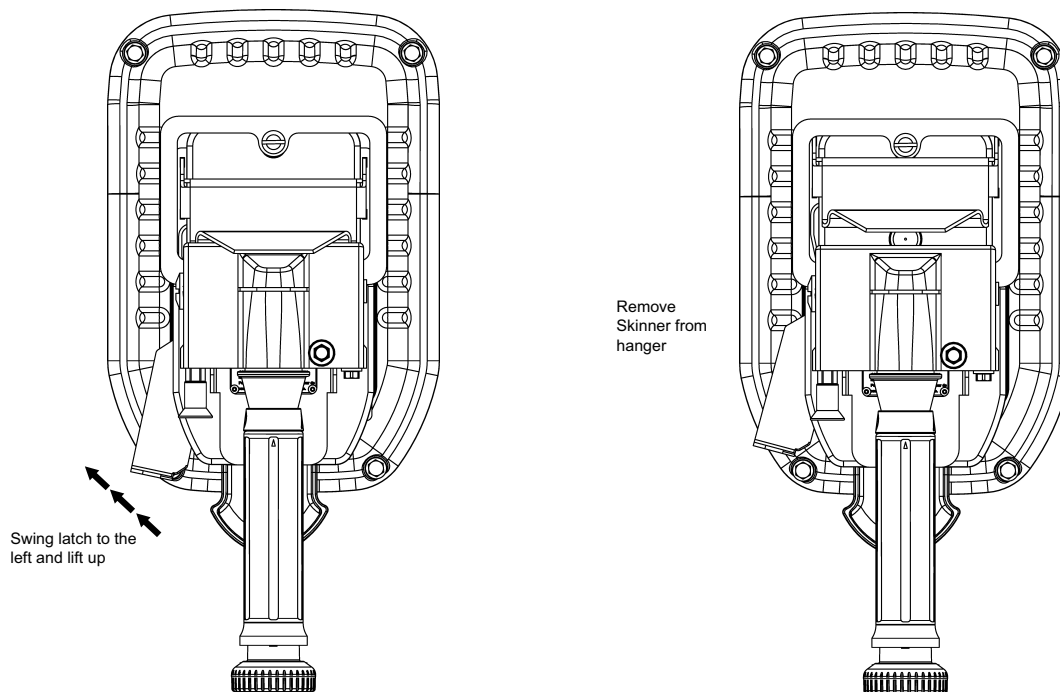

TURNING ON THE WHIZARD QUANTUM[®] DRIVE

To turn **ON** the Whizard Quantum[®] Drive:

1. If necessary, remove handpiece from hanger.
2. Pull down on switch lever.

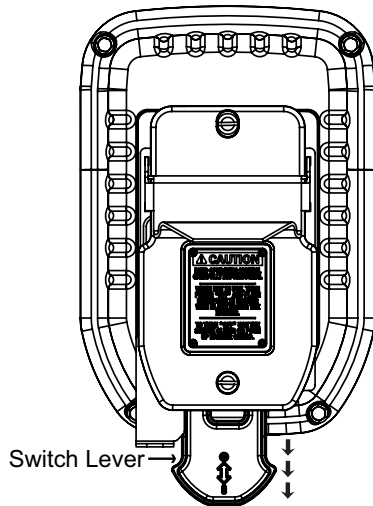

Pull down switch lever to turn unit **ON**

TURNING OFF THE WHIZARD QUANTUM[®] DRIVE

There are 2 ways to turn **OFF** the Whizard Quantum[®] Drive:

1. Push up on switch lever.
2. Lift latch/handpiece bracket with your hand or place front portion of the skinner in the "lip" area of handpiece bracket and lift up on handpiece bracket with skinner in hand.

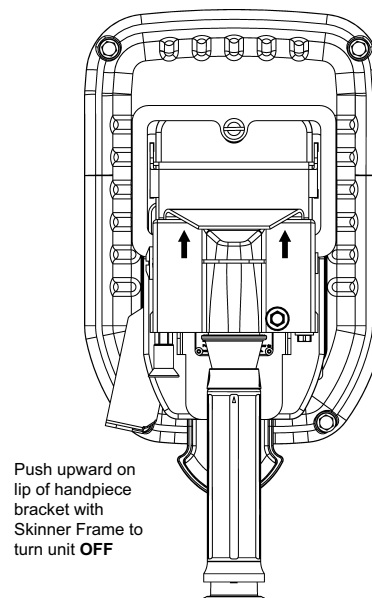
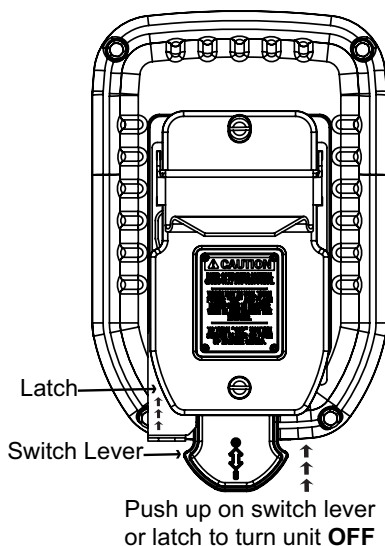

THIS PAGE INTENTIONALLY LEFT BLANK

Section 5

Maintenance

CONTENTS OF THIS SECTION

Disassembly	5-2
Power Cord Replacement	5-5
Controller Replacement	5-8
Motor Replacement	5-11
Disconnect Assembly Replacement / Repair	5-17
Replacement	5-21
Repair	5-22
Reassemble	5-24
Switch Replacement	5-27
Fuse Replacement	5-31
Fault Detection and Correction	5-32



WARNING



To avoid personal injury, always disconnect the power cord before performing any adjustments, disassembly/assembly, troubleshooting or cleaning.

Always disconnect the power and remove the tool from the driveline prior to servicing.

All electrical repairs should be completed by a qualified electrician or approved service provider.

DISASSEMBLY

 **WARNING**

To avoid personal injury, always disconnect the power cord before performing any adjustments, disassembly/assembly, troubleshooting or cleaning.



Always disconnect the power and remove the tool from the driveline prior to servicing.

All electrical repairs should be completed by a qualified electrician or approved service provider.

1. Unplug power and remove motor assembly from support yoke by pivoting and lifting as shown.

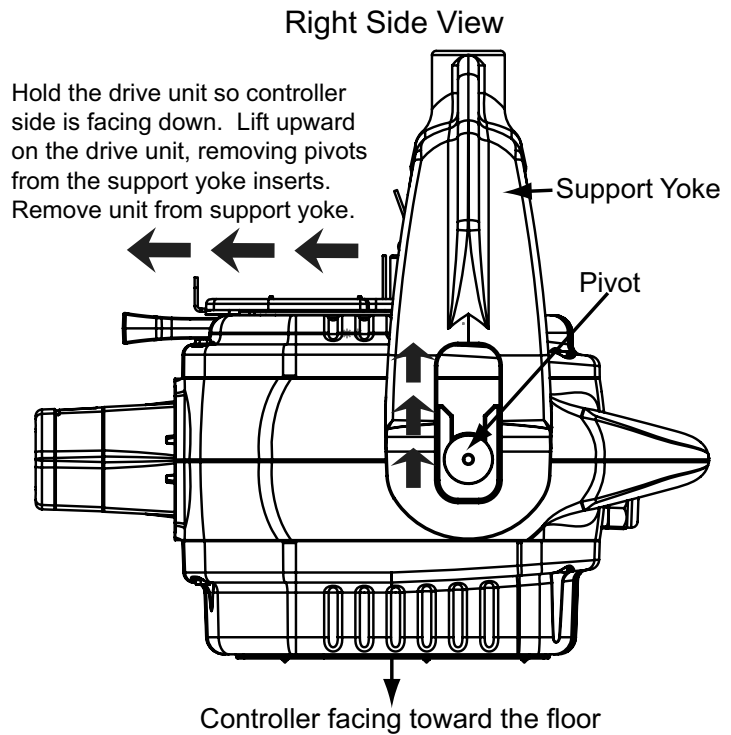
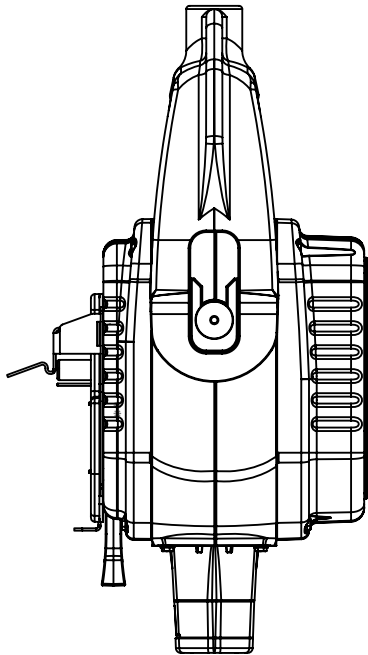

DISASSEMBLY (CONTINUED)

2. Remove 4 screws and washers from rear cover.
3. Disconnect switch wire terminals inside motor housing.
4. To access and disassemble the controller, lay cover on its back and remove 5 screws and washers that hold controller cover on the electrical enclosure.

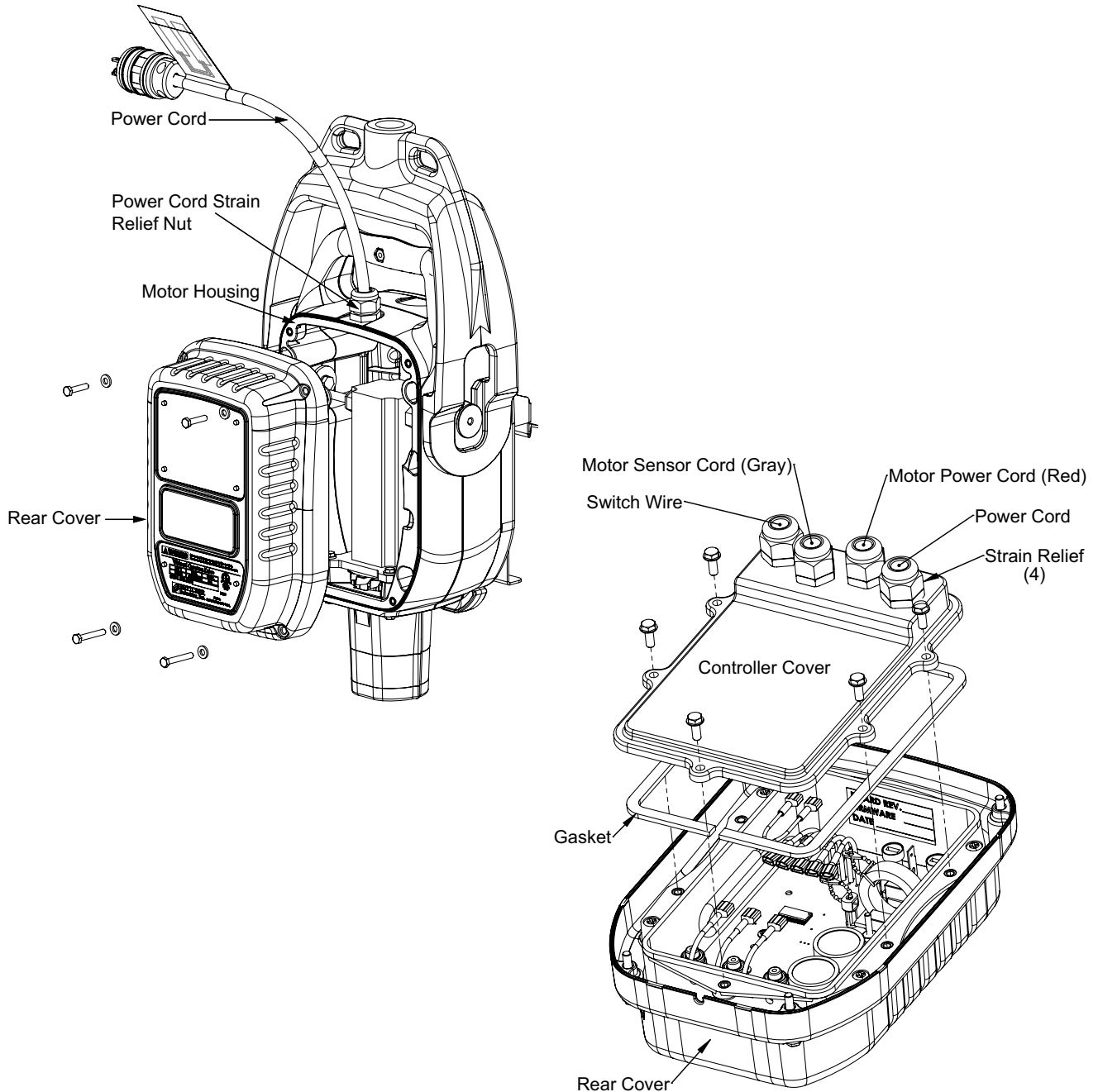

DISASSEMBLY (CONTINUED)

5. Loosen all 4 strain relief nuts on back of controller cover.
6. Feed wires through strain reliefs as you open the cover.

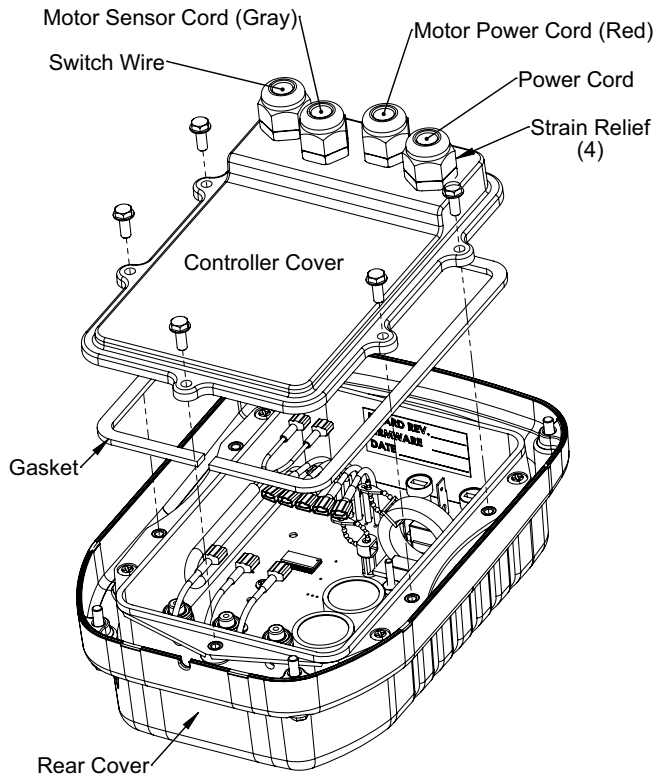

**Assembly is the reversal of these directions.*

POWER CORD REPLACEMENT

! WARNING



To avoid personal injury, always disconnect the power cord before performing any adjustments, disassembly/assembly, troubleshooting or cleaning.

Always disconnect the power and remove the tool from the driveline prior to servicing.

All electrical repairs should be completed by a qualified electrician or approved service provider.

1. Disassemble unit. *Refer to Section 5, Disassembly.*
2. Disconnect the power cord by pulling the **L** and **N** spade connectors from the board terminal.
3. Remove ground wire retaining nut **G** by holding a wrench on the bottom nut and loosening the top nut.
4. Remove remaining nuts (2), ring connectors (4), and lock washers (6).
5. Open reusable, beaded cable ties.

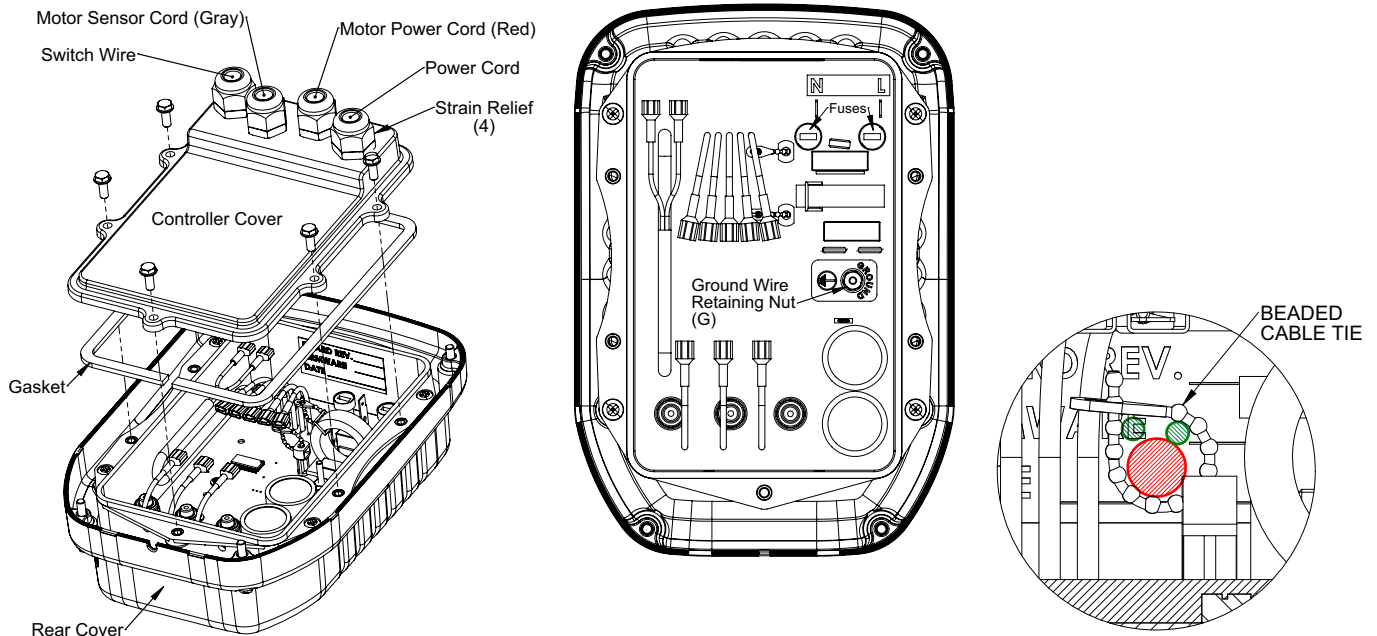

POWER CORD REPLACEMENT (CONTINUED)

6. Remove power cord through strain relief on controller cover and through strain relief in motor housing.
7. Feed new power cord through strain relief on motor housing and through power cord strain relief on controller cover.
8. Attach black wire of power cord to **L** terminal in controller box, white wire to **N** terminal, and green wire to ground post **G**. See *below* for ground assembly. Torque all 3 nuts to 10-12 lb-in.
9. Tighten both beaded cable ties around power ground wire cord, motor sensor cord ground wire, and motor sensor cord.

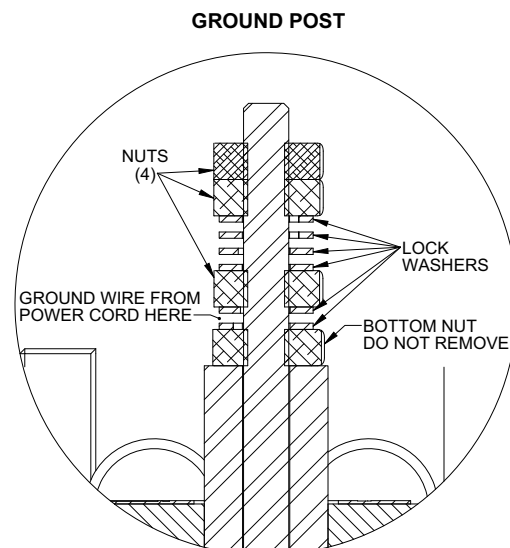
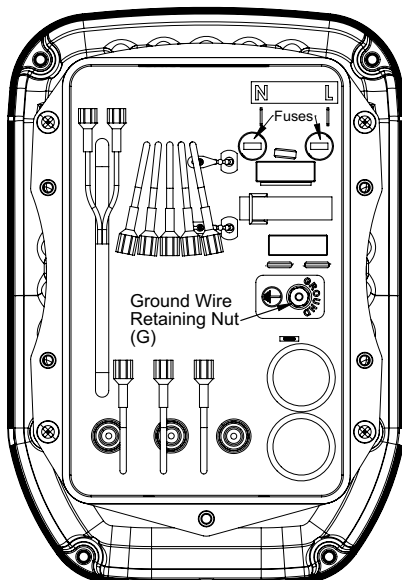
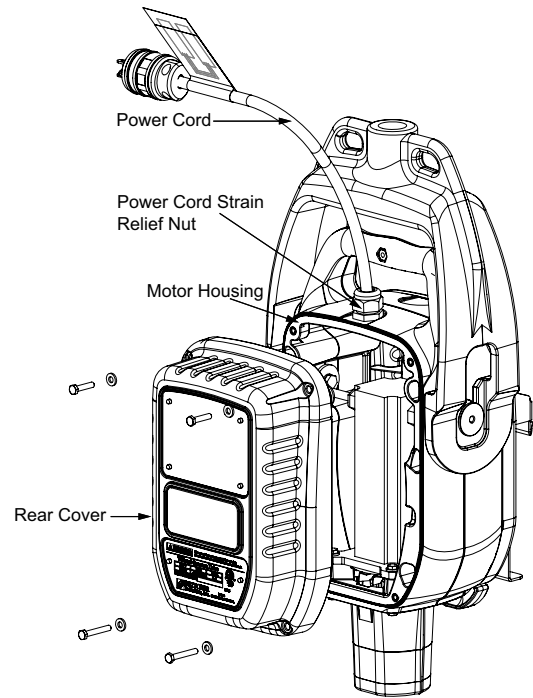
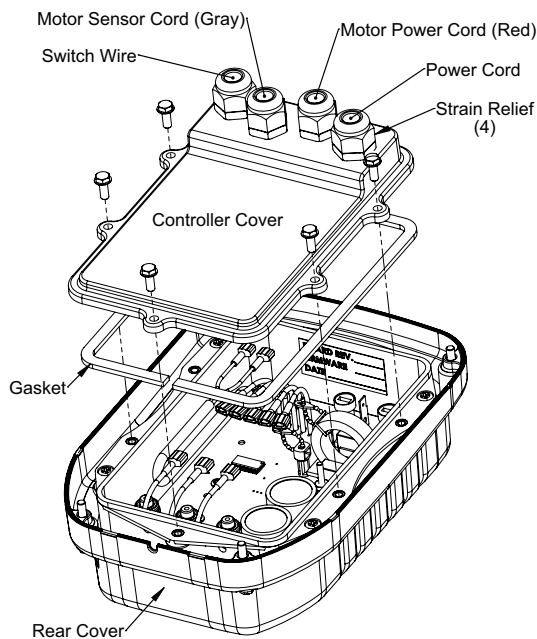

POWER CORD REPLACEMENT (CONTINUED)

10. Attach controller cover using 5 screws. *Apply Loctite 242 to screws then torque to 30-35 lb-in.*
11. Tighten strain reliefs on controller cover.
12. Reconnect switch wires to corresponding terminals inside motor housing.
13. Reassemble drive unit by attaching rear cover to motor housing using 4 washers and screws. *Apply Loctite 242 to screws then torque to 30-35 lb-in.*
14. Tighten power cord strain relief on motor housing.

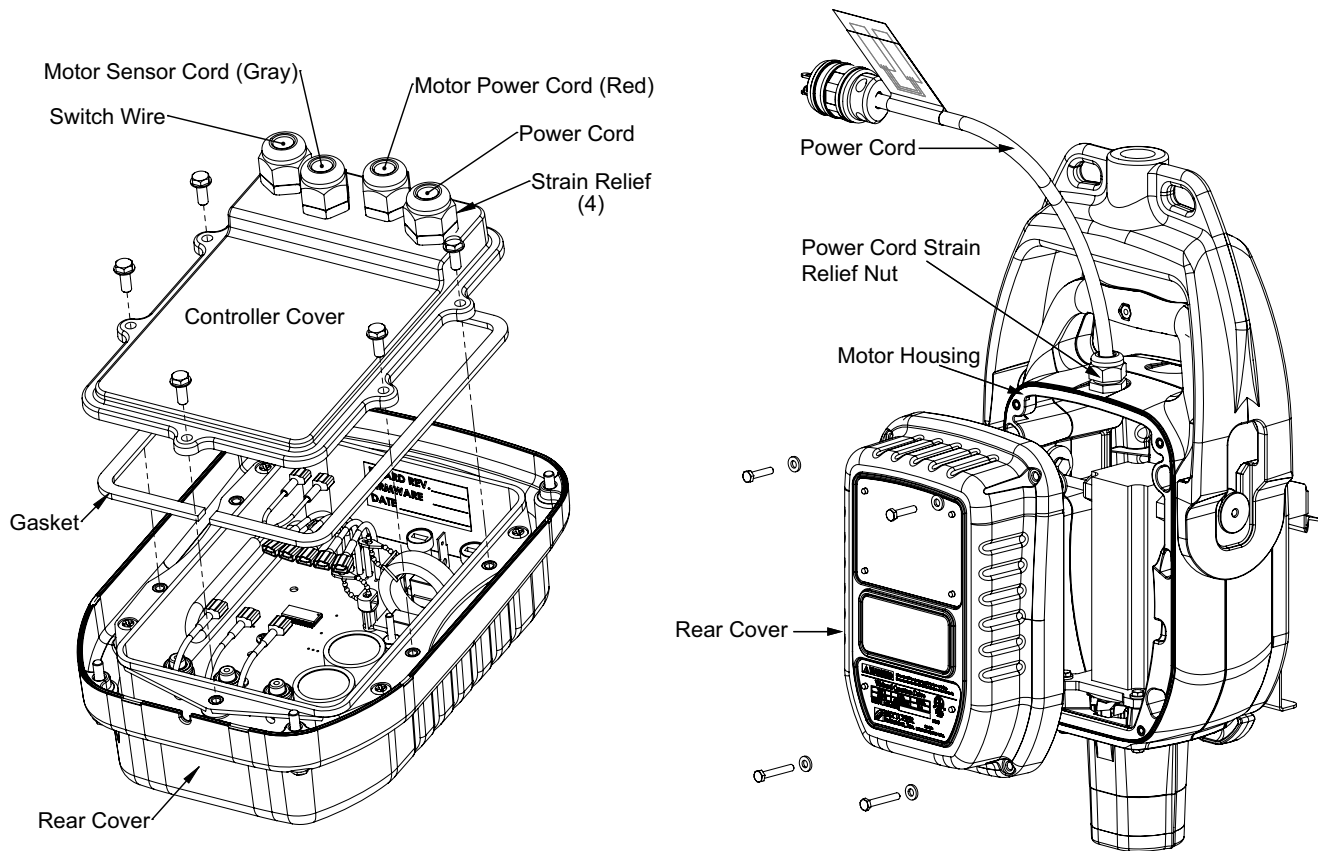

CONTROLLER REPLACEMENT

 **WARNING**

To avoid personal injury, always disconnect the power cord before performing any adjustments, disassembly/assembly, troubleshooting or cleaning.



Always disconnect the power and remove the tool from the driveline prior to servicing.

All electrical repairs should be completed by a qualified electrician or approved service provider.

1. Disassemble unit. Refer to Section 5, Disassembly.
2. Disconnect motor sensor cord, motor power cord, and power cord cable wires L, N and G.

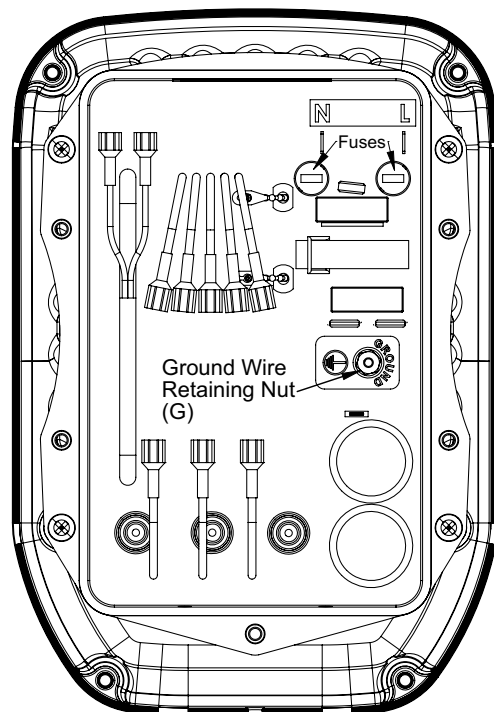
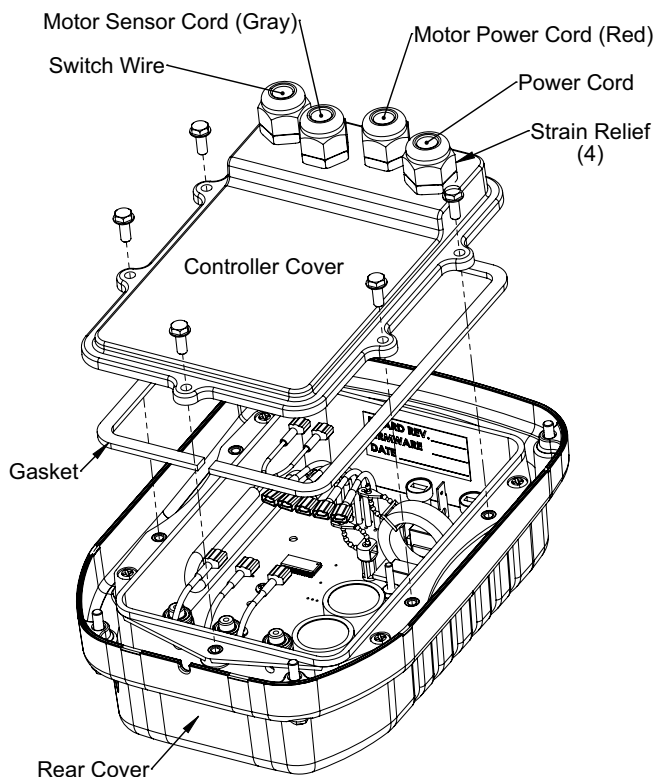

CONTROLLER REPLACEMENT (CONTINUED)

3. Feed switch wire terminals trough strain relief one at a time to completely remove controller cover.
4. Remove controller from rear cover by removing 4 screws.
5. Place new seal and controller in rear cover. Attach controller to rear cover using 4 screws.
- Torque to 20-25 lb-in.*
6. Insert switch wire terminals through designated strain relief one at a time.
7. Reconnect motor sensor cord, motor power cord, and power cord cable wires **L**, **N**, and **G**.

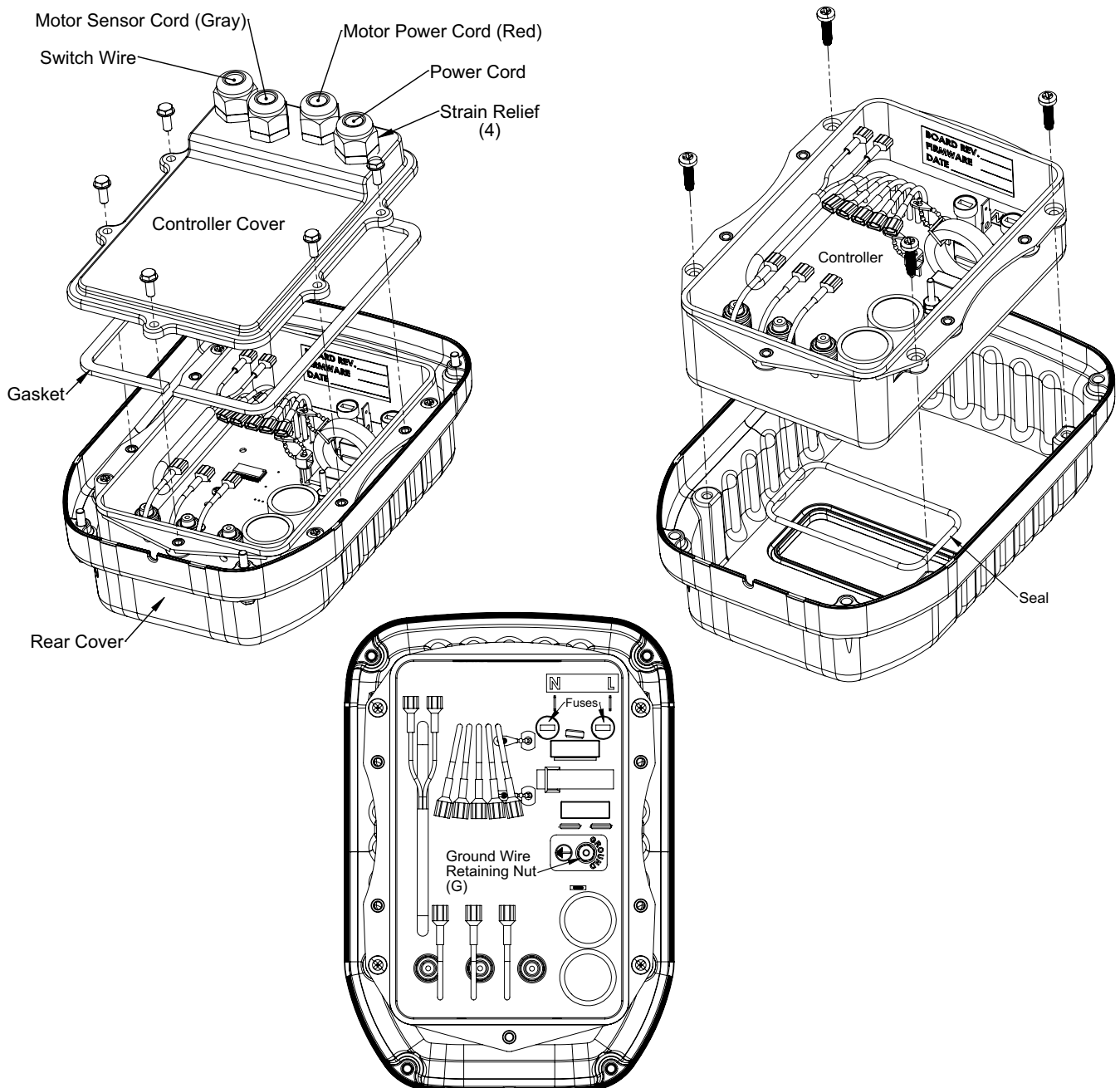

CONTROLLER REPLACEMENT (CONTINUED)

8. Attach controller cover using 5 screws. *Apply Loctite 242 to screws then torque to 30-35 lb-in.*
9. Tighten strain reliefs on controller cover.
10. Reconnect switch wire terminals to corresponding terminals in motor housing.
11. Reassemble drive unit by attaching rear cover to motor housing using 4 washers and screws. *Apply Loctite 242 to screws then torque to 30-35 lb-in.*

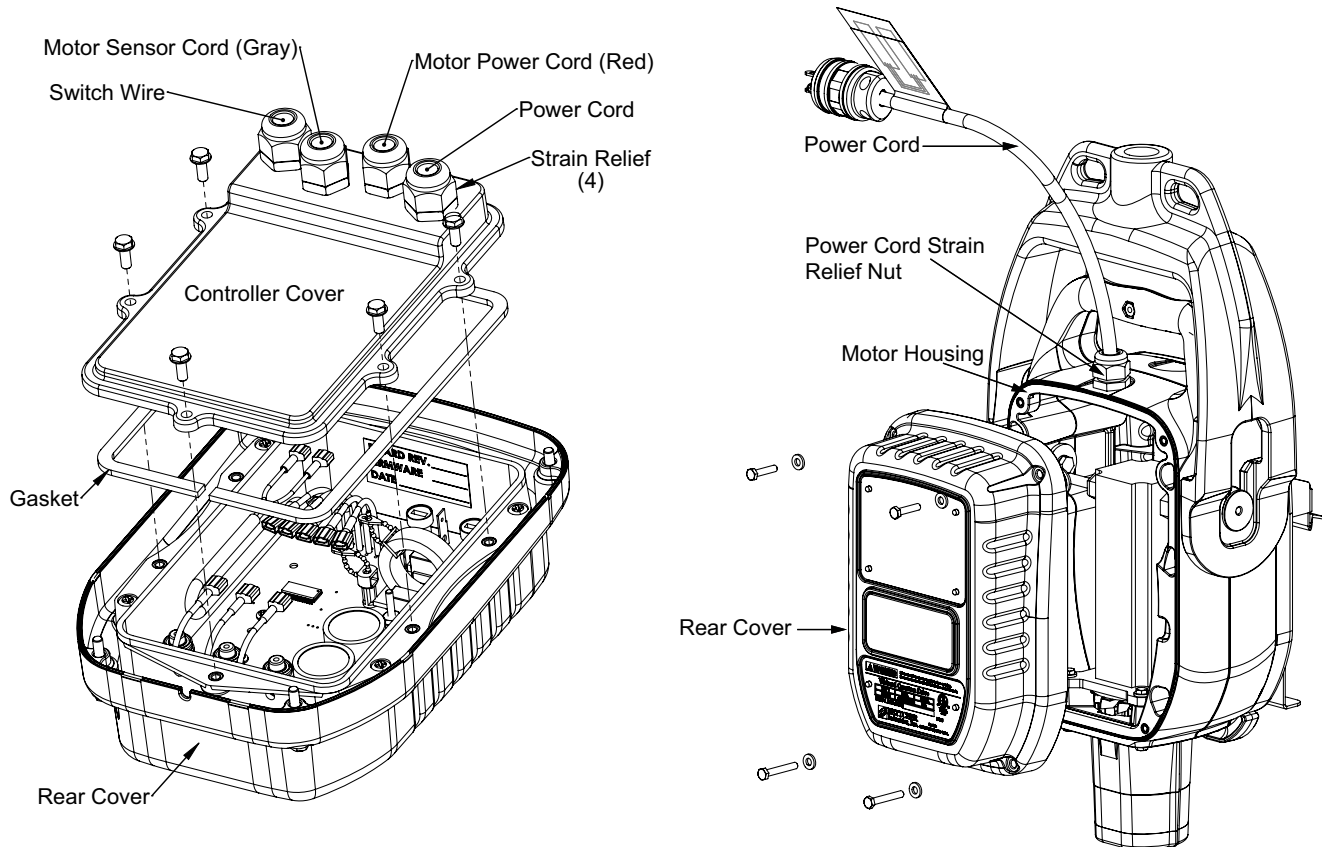

MOTOR REPLACEMENT

 **WARNING**

To avoid personal injury, always disconnect the power cord before performing any adjustments, disassembly/assembly, troubleshooting or cleaning.



Always disconnect the power and remove the tool from the driveline prior to servicing.

All electrical repairs should be completed by a qualified electrician or approved service provider.

1. Disassemble unit. *Refer to Section 5, Disassembly.*
2. Disconnect motor sensor cord and motor power cord. **Note:** *Wire terminals will not fit through strain reliefs. Completely remove motor sensor and power cord strain reliefs to remove wires.*

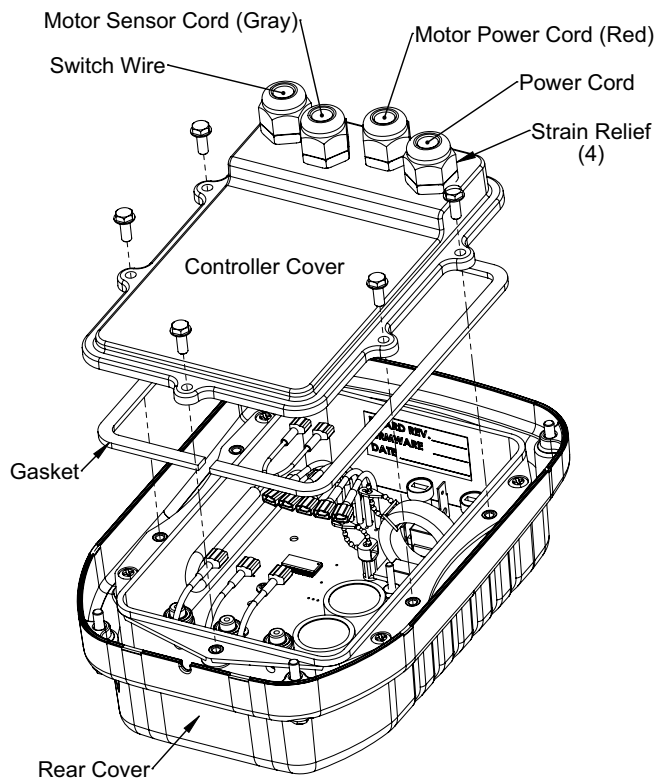

MOTOR REPLACEMENT (CONTINUED)

3. Remove 4 screws and washers from bottom of motor support plate.
4. Lift motor assembly out of the motor housing.

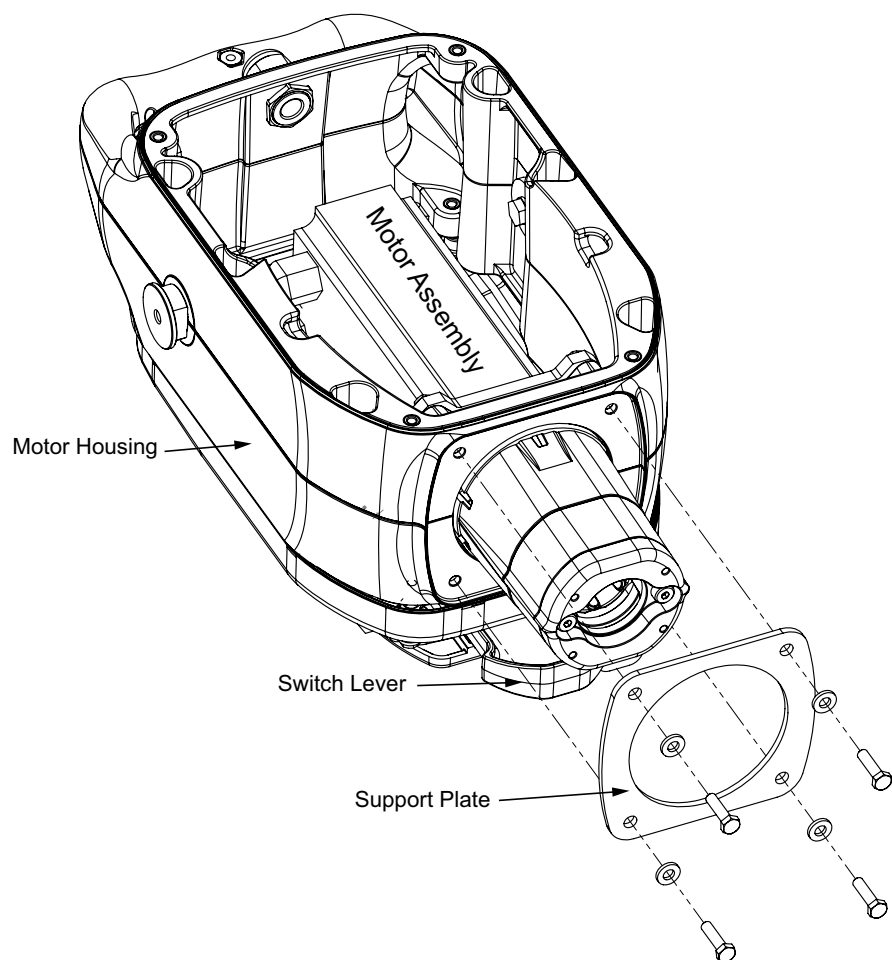

MOTOR REPLACEMENT (CONTINUED)

5. Remove disconnect assembly from bottom of motor by removing 4 screws and washers from motor flange.
6. Remove and save drive adapter by loosening 2 set screws and pulling drive adapter off end of motor shaft.
7. Remove and save motor fan by loosening set screw.

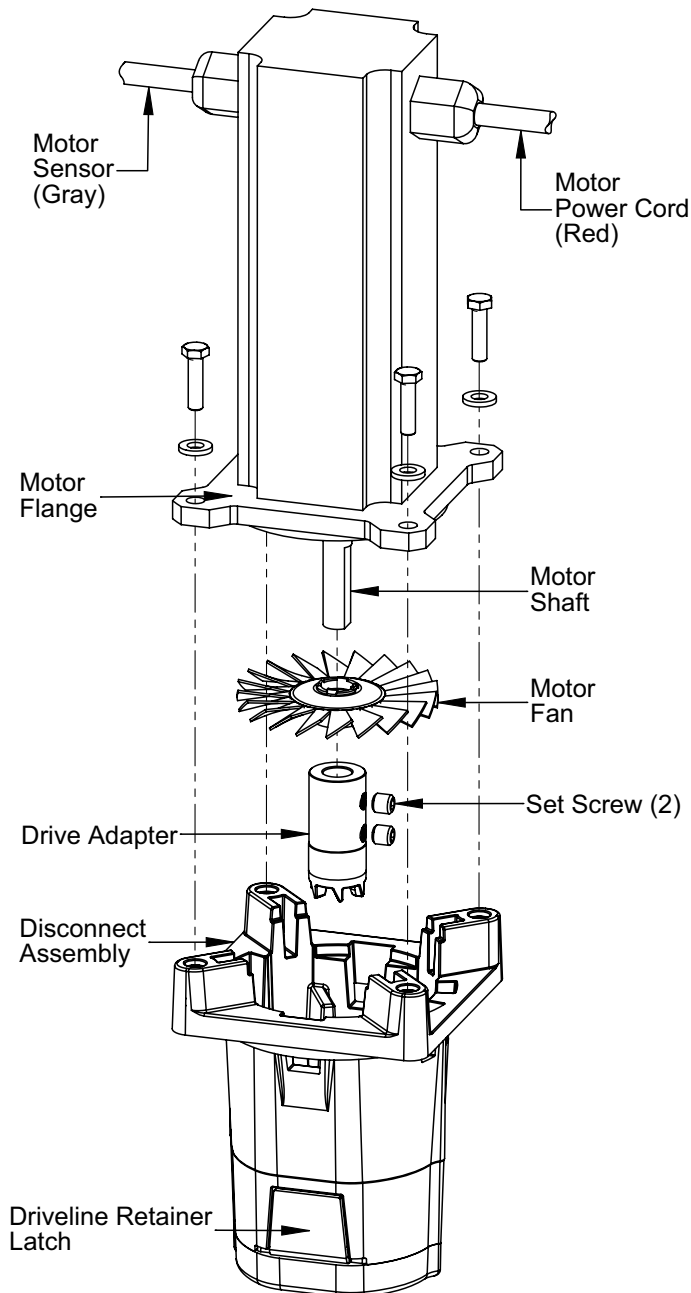

MOTOR REPLACEMENT (CONTINUED)

8. Mount motor fan to new motor shaft using set screw. Apply Loctite 242 to screw then torque to 30-35 lb-in.

IMPORTANT: When mounting fan to the new motor, leave a gap of .030 in. between the fan hub and motor face.

9. Mount drive adapter to the flat side of the motor shaft using 2 set screws. Apply Loctite 242 to screws then torque to 55-60 lb-in.

IMPORTANT: Apply anti-seize to motor shaft before mounting drive adapter. When mounting drive adapter to the motor shaft, leave 2.380 - 2.370 inches from the drive face to the motor flange.

10. With driveline retainer latch facing forward and motor power cord (Red) on the right, align holes of disconnect assembly to holes in motor flange. Attach using 4 washers and screws. Torque to 30-35 lb-in.

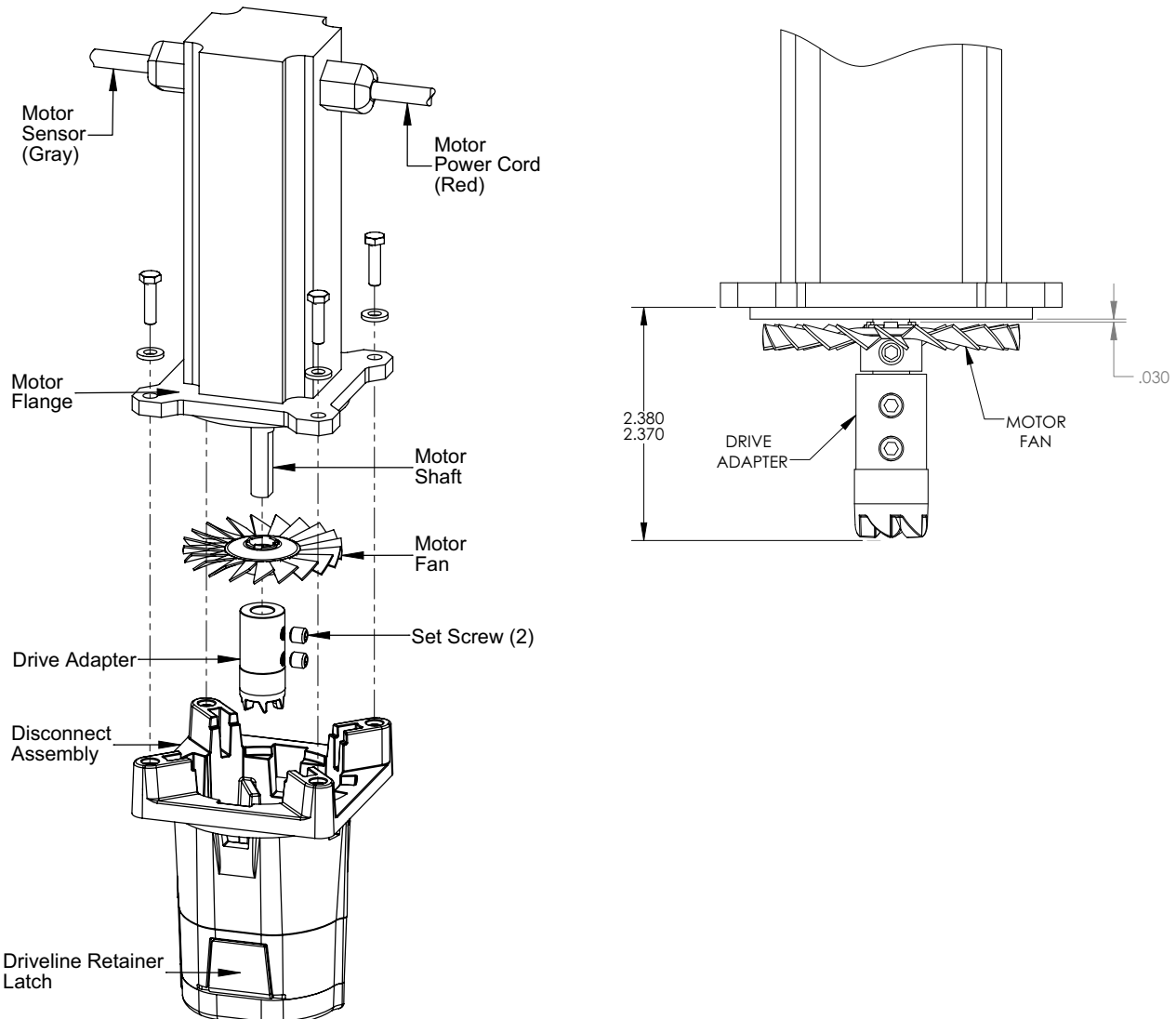

MOTOR REPLACEMENT (CONTINUED)

11. With driveline retainer latch facing switch lever, place motor assembly into motor housing.
12. Attach support plate using 4 washers and screws. *Torque to 30-35 lb-in.*

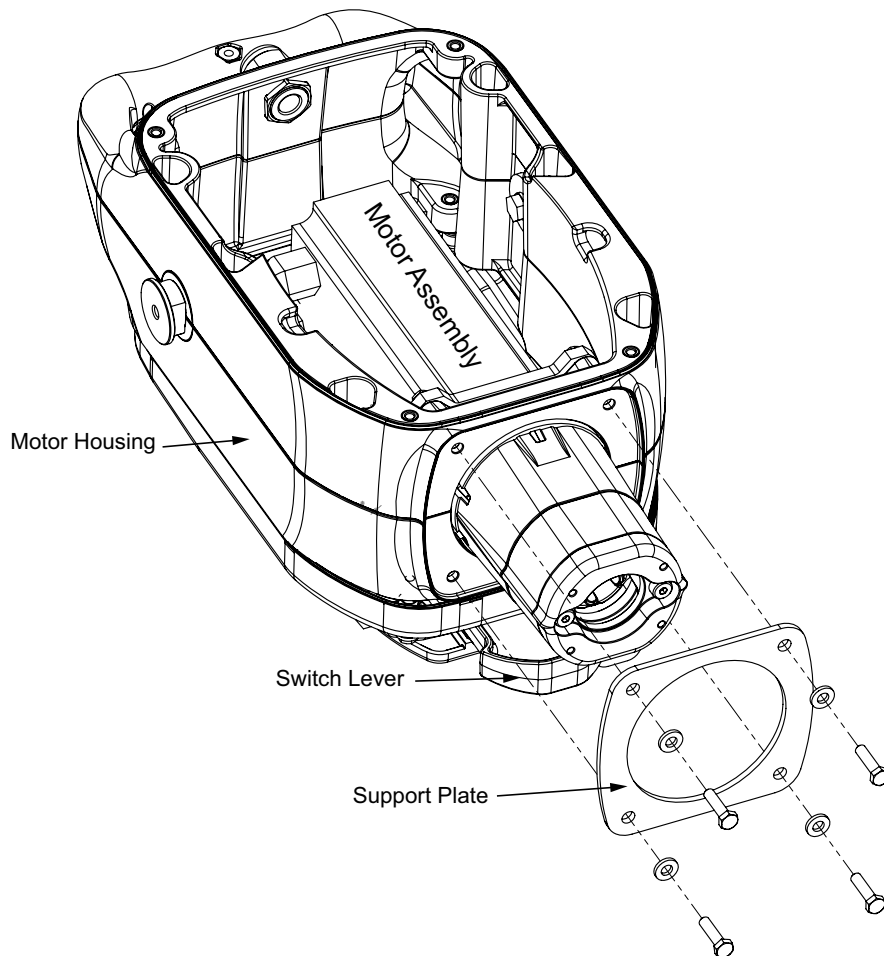

MOTOR REPLACEMENT (CONTINUED)

13. Feed motor sensor cord and motor power cord wire terminals with strain reliefs into controller cover.
14. Attach strain relief lock nuts to back of controller cover.
15. Connect motor sensor cord and motor power cord wire terminals to corresponding controller wires.
16. Attach controller cover using 5 screws. *Apply Loctite 242 to screws then torque to 30-35 lb-in.*
17. Tighten strain reliefs on controller cover.
18. Reconnect switch wire terminals to corresponding terminals in motor housing.
19. Reassemble drive unit by attaching rear cover to motor housing using 4 washers and screws. *Apply Loctite 242 to screws then torque to 30-35 lb-in.*

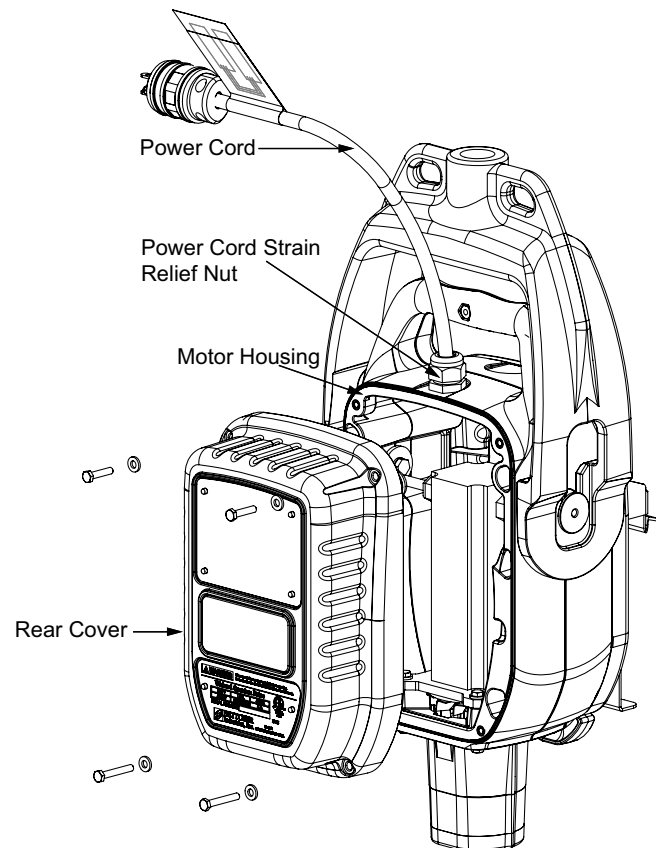
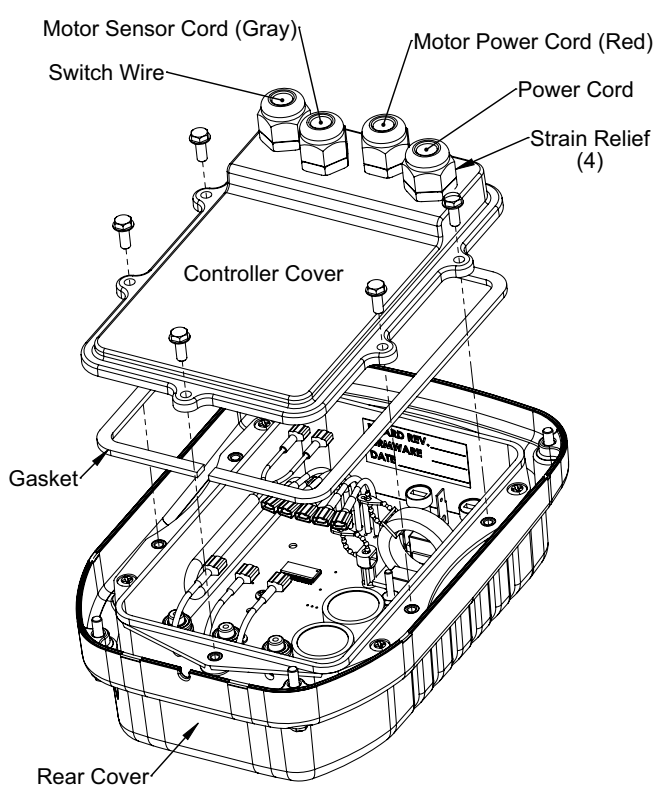

DISCONNECT ASSEMBLY REPLACEMENT / REPAIR

 **WARNING**

To avoid personal injury, always disconnect the power cord before performing any adjustments, disassembly/assembly, troubleshooting or cleaning.



Always disconnect the power and remove the tool from the driveline prior to servicing.

All electrical repairs should be completed by a qualified electrician or approved service provider.

1. Unplug power and remove motor assembly from support yoke by pivoting and lifting as shown.

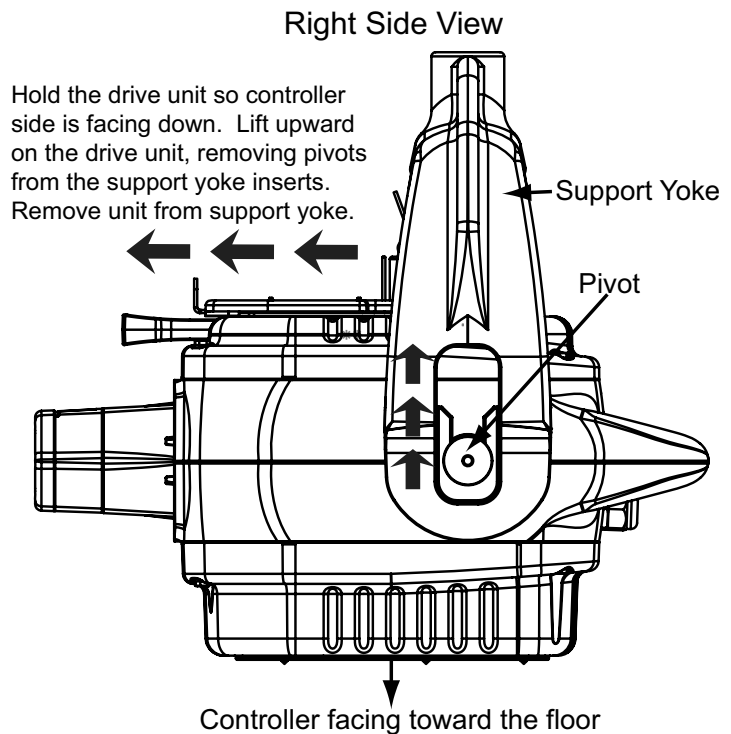
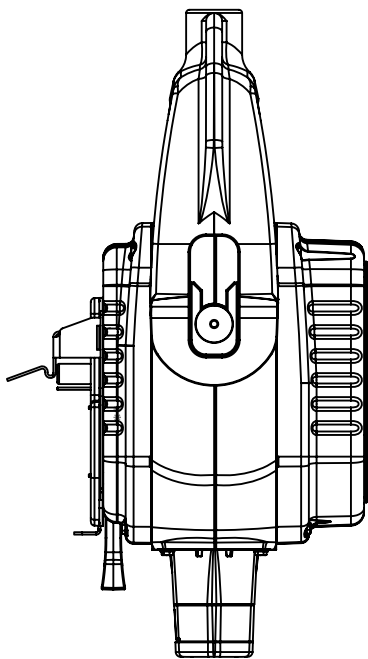

DISCONNECT ASSEMBLY REPLACEMENT / REPAIR (CONTINUED)

2. Remove 4 screws and washers from rear cover.
3. Loosen power cord strain relief nut.
4. Feed power cord through power cord strain relief as you open rear cover.
5. Disconnect switch wire terminals inside motor housing.

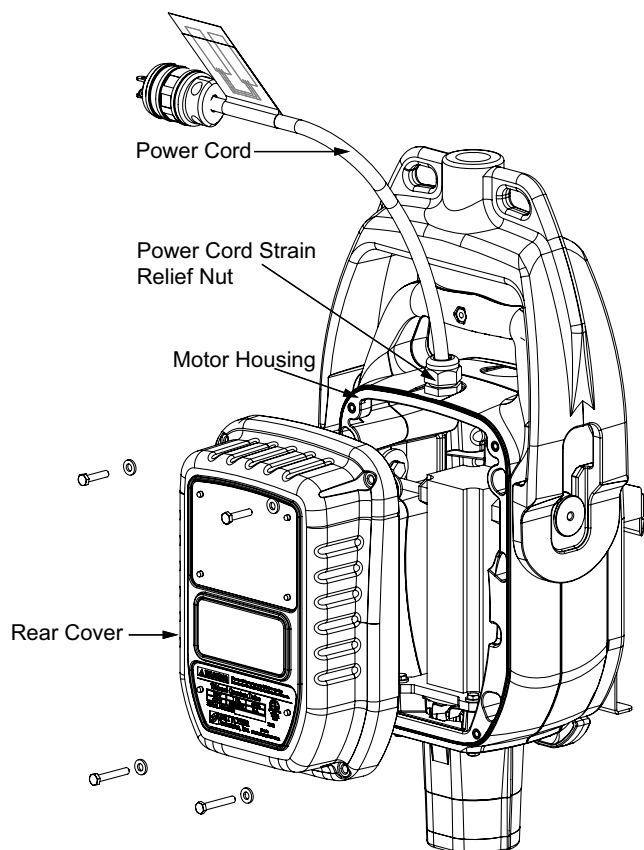

DISCONNECT ASSEMBLY REPLACEMENT / REPAIR (CONTINUED)

6. Remove 4 screws and washers from bottom of motor support plate.
7. Lift motor assembly and attached rear cover/controller out of the motor housing.

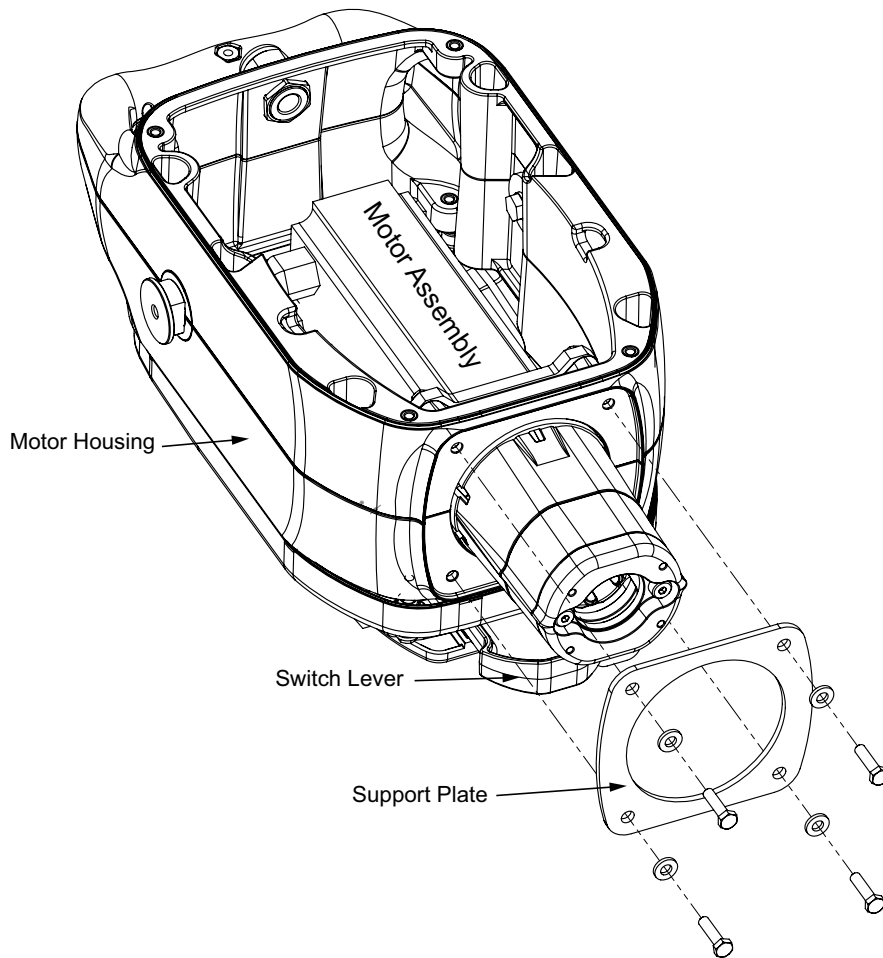

DISCONNECT ASSEMBLY REPLACEMENT / REPAIR (CONTINUED)

8. Remove disconnect assembly from bottom of motor by removing 4 screws and washers from motor flange.

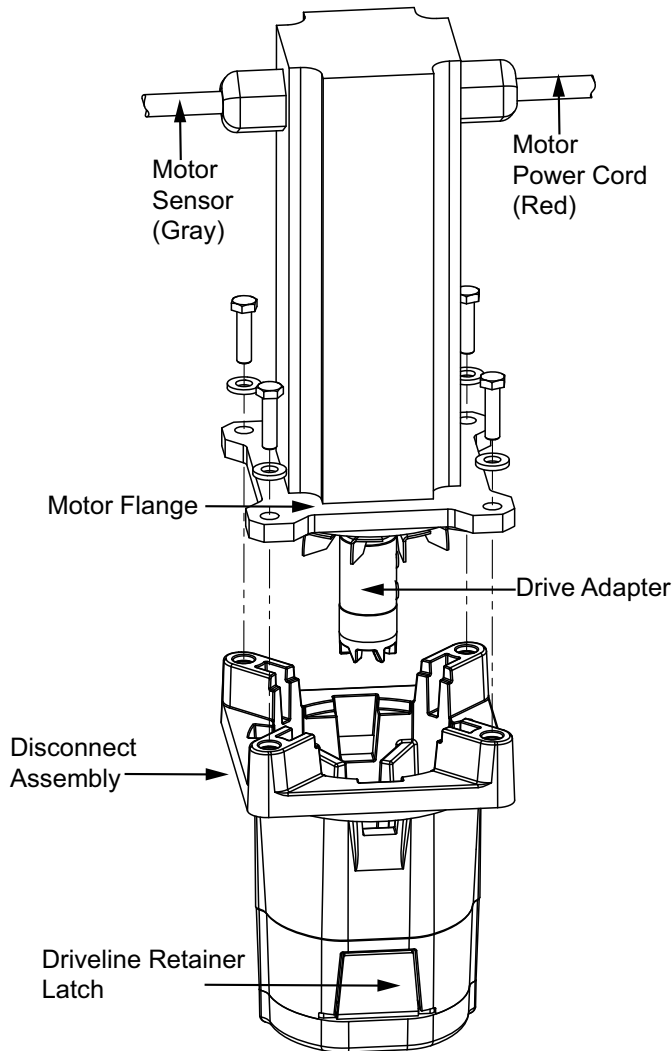

Rear cover/controller not shown

DISCONNECT ASSEMBLY REPLACEMENT / REPAIR (CONTINUED)

Replacement

1. With driveline retainer latch facing forward and motor power cord (Red) on the right, align holes of new disconnect assembly to holes in motor flange. Attach using 4 washers and screws. *Torque to 30-35 lb-in.*

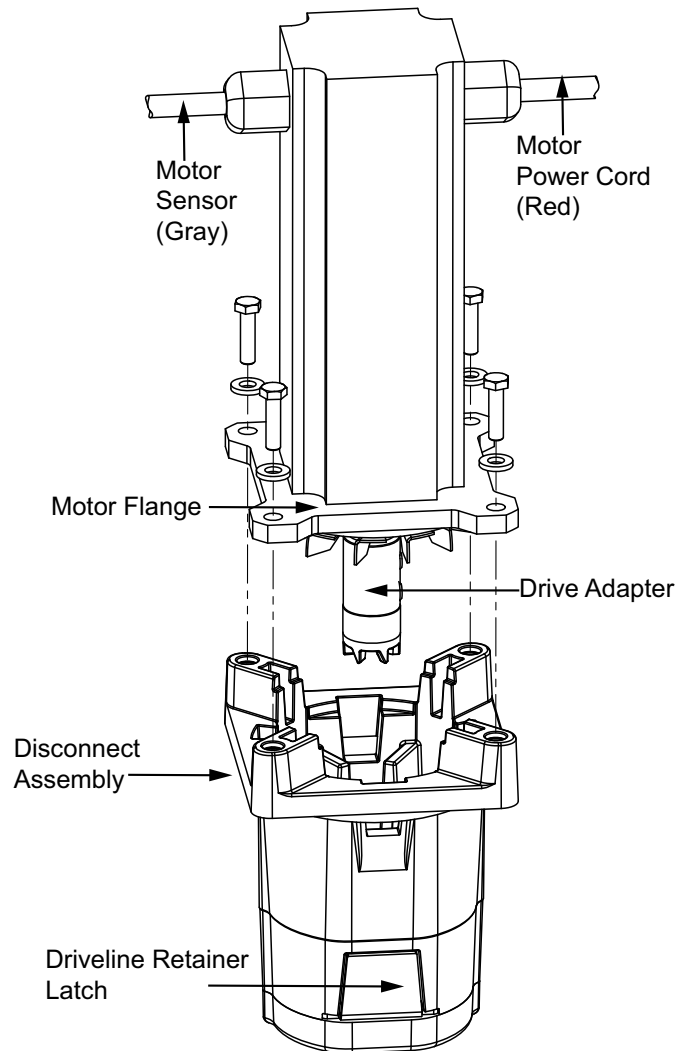

Rear cover/controller not shown

DISCONNECT ASSEMBLY REPLACEMENT / REPAIR (CONTINUED)

Repair

DISASSEMBLE DISCONNECT ASSEMBLY

1. Using a 1/8" allen wrench, remove the two screws located inside the upper housing of the disconnect assembly.
2. Disassemble the components of the disconnect assembly.
3. Inspect and replace worn part(s).

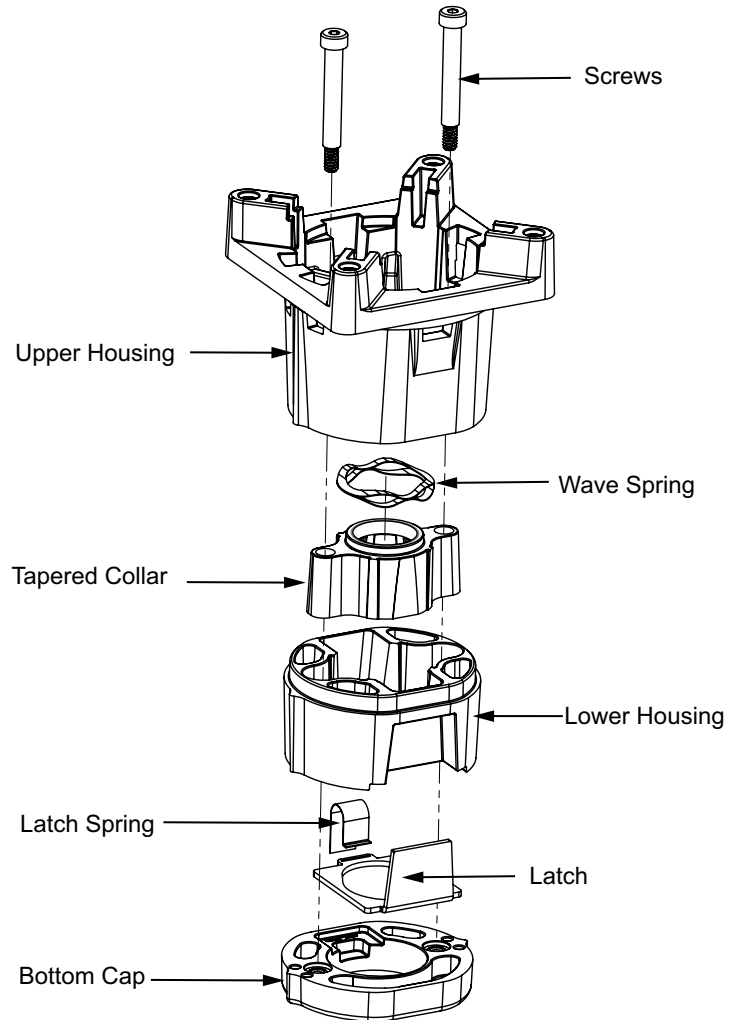

DISCONNECT ASSEMBLY REPLACEMENT / REPAIR (CONTINUED)

Repair (Continued)

ASSEMBLE DISCONNECT ASSEMBLY

1. Place latch spring into latch slot.
2. Set assembled latch and spring onto bottom cap. *Make certain spring leg fits into pocket of bottom cap.* This is the base for the disconnect assembly.
3. Carefully align and stack lower housing, tapered collar, wave spring, and upper housing onto base. *Make certain latch and tapered collar move freely.*
4. Place screws into holes located inside upper housing. **NOTICE:** Do not force screws into disconnect assembly. Screws should freely drop into place when components are correctly aligned.
5. Test latch to make certain it moves freely before tightening screws.
6. Tighten screws. *Torque to 15-18 lb-in.*

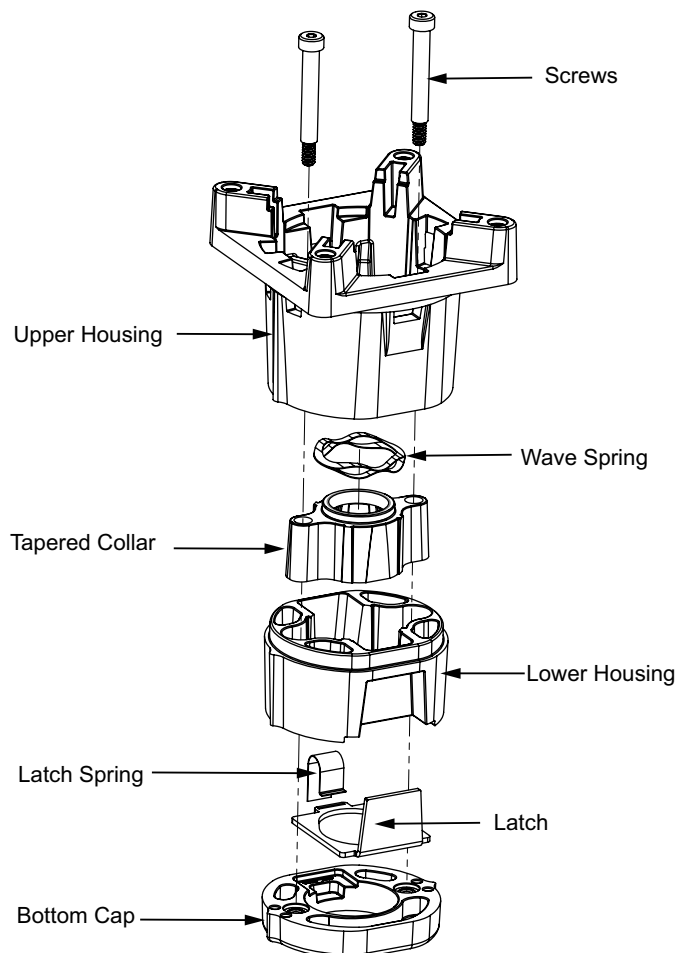
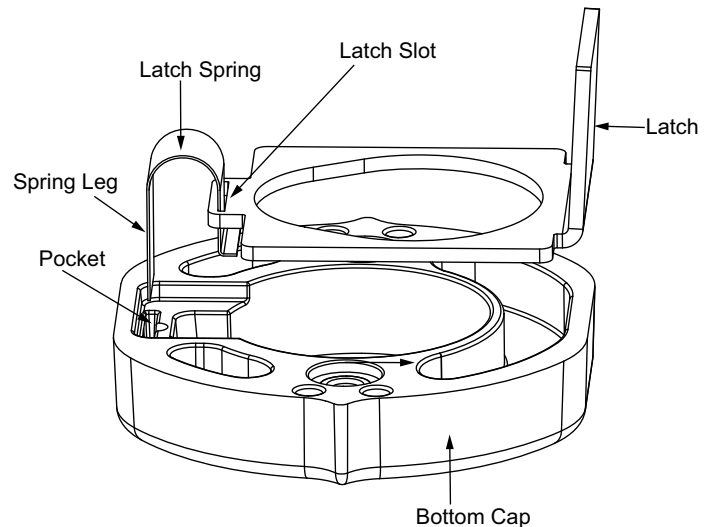

DISCONNECT ASSEMBLY REPLACEMENT / REPAIR (CONTINUED)

Reassemble

1. With driveline retainer latch facing forward and motor power cord (Red) on the right, align holes of disconnect assembly to holes in motor flange. Attach using 4 washers and screws. *Torque to 30-35 lb-in.*

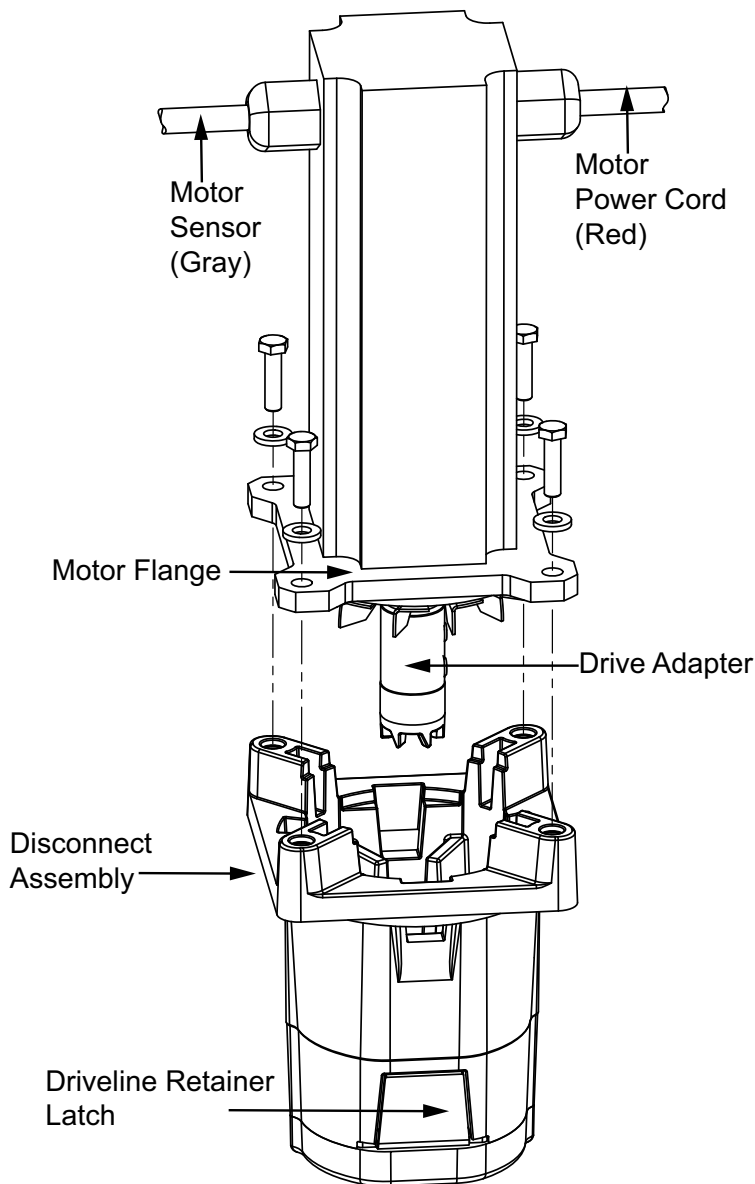

Rear cover/controller not shown

DISCONNECT ASSEMBLY REPLACEMENT / REPAIR (CONTINUED)

2. With driveline retainer latch facing switch lever, place motor assembly and rear cover/controller into motor housing.
3. Attach support plate using 4 washers and screws. *Torque to 30-35 lb-in.*

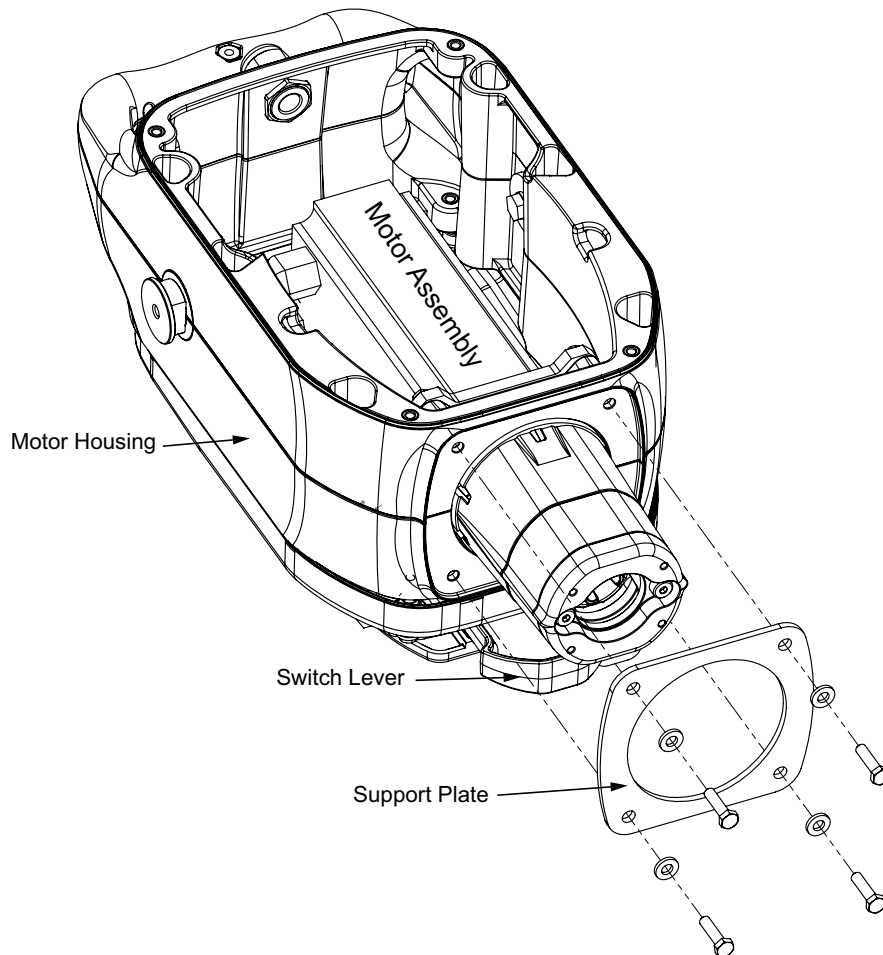

DISCONNECT ASSEMBLY REPLACEMENT / REPAIR (CONTINUED)

4. Reconnect switch wire terminals to corresponding terminals in motor housing.
5. Reassemble drive unit by attaching rear cover to motor housing using 4 washers and screws. *Apply Loctite 242 to screws then torque to 30-35 lb-in.*

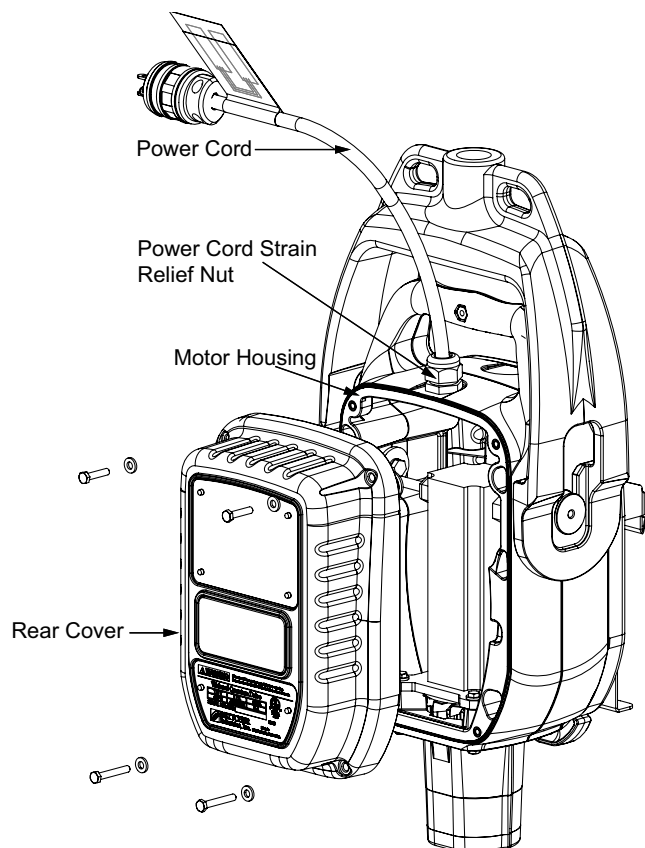

SWITCH REPLACEMENT

 **WARNING**



To avoid personal injury, always disconnect the power cord before performing any adjustments, disassembly/assembly, troubleshooting or cleaning.

Always disconnect the power and remove the tool from the driveline prior to servicing.

All electrical repairs should be completed by a qualified electrician or approved service provider.

1. Unplug power and remove motor assembly from support yoke by pivoting and lifting as shown.

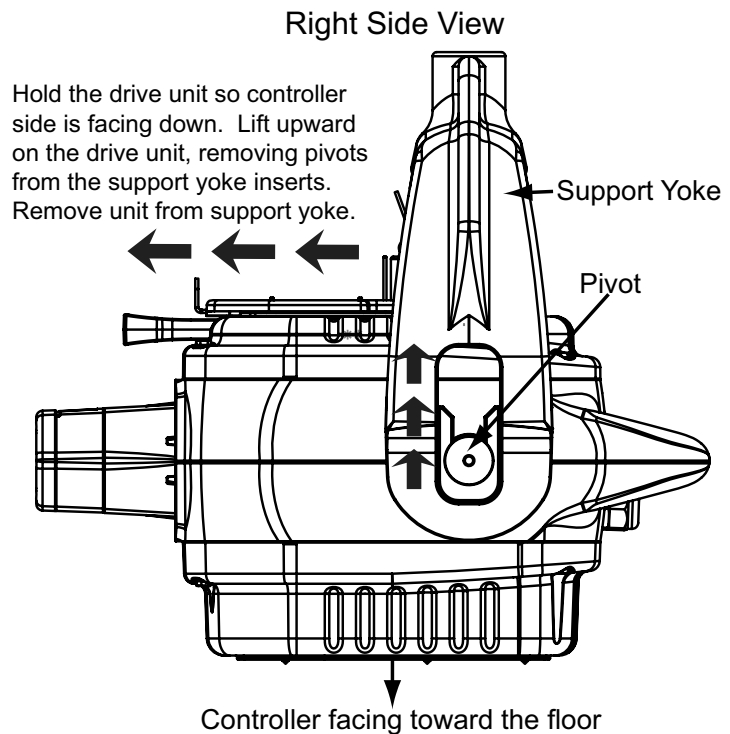
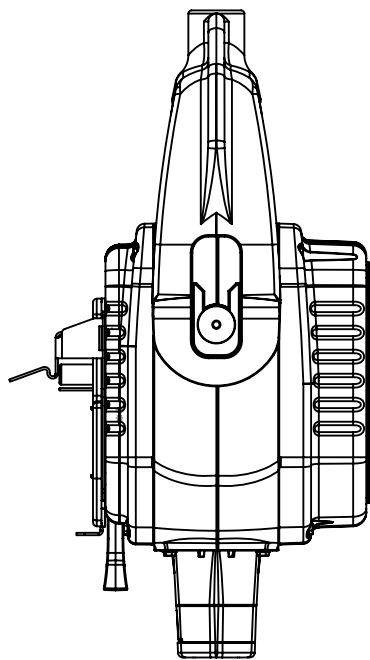

SWITCH REPLACEMENT (CONTINUED)

2. Remove 4 screws and washers from front cover.
3. Disconnect switch wires by carefully disconnecting wire terminals inside motor housing.

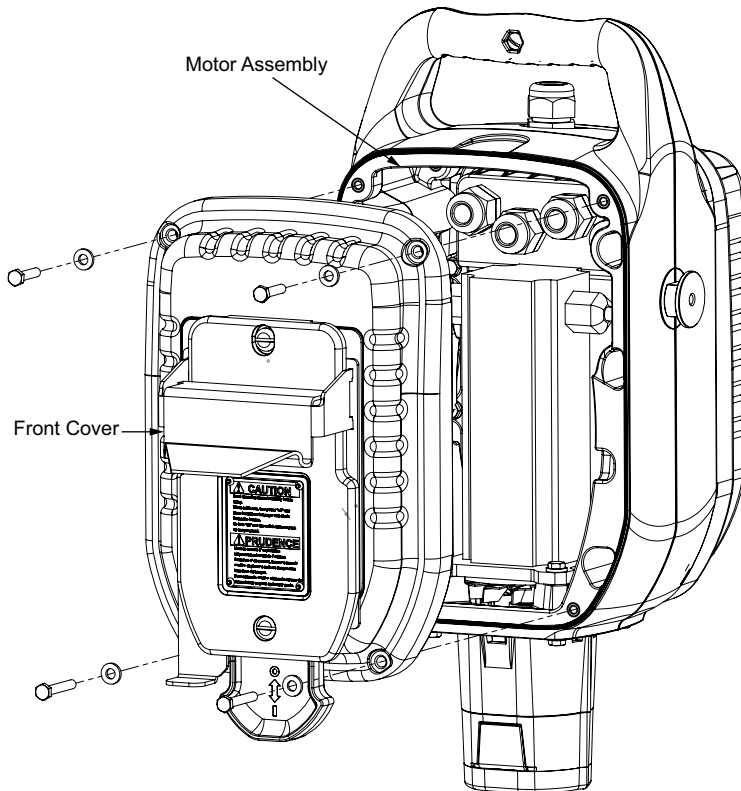

SWITCH REPLACEMENT (CONTINUED)

4. Remove 2 striker plate screws to remove skinner hanger, striker plate, peg, guard assembly and cover plate.
5. To remove switch, remove 2 screws and retaining plate from switch assembly. Remove old switch by pulling switch wires through the access hole in the switch assembly.
6. Feed new switch wires through access hole in switch assembly.

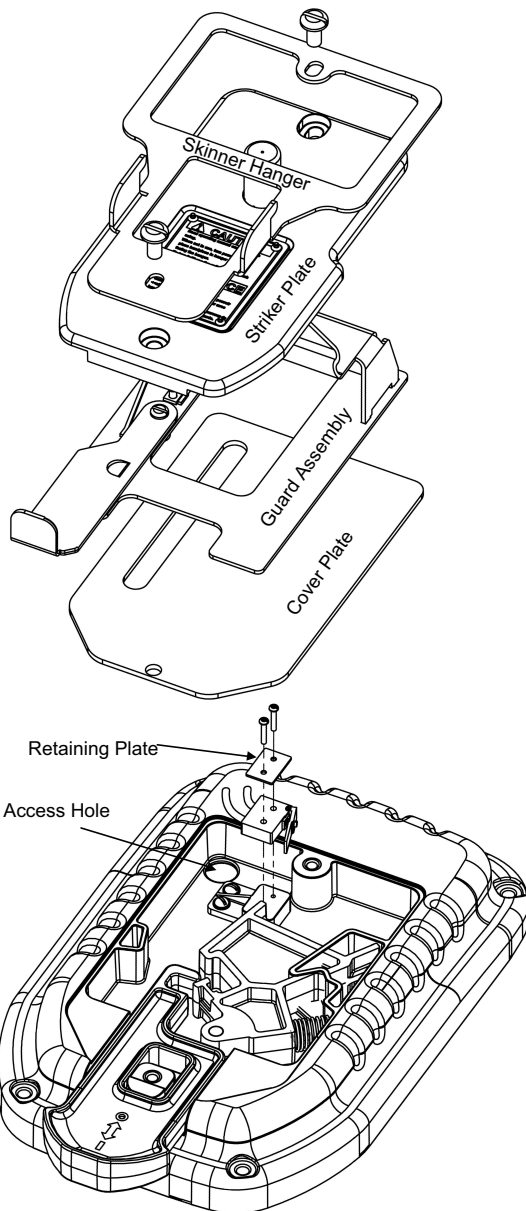

SWITCH REPLACEMENT (CONTINUED)

7. Attach switch using 2 screws and retaining plate. Position the retaining plate so that it covers the switch lever hinge point. *Apply Loctite 222 MS to screws then torque to 3 lb-in.*
8. Reinstall cover plate, guard assembly, peg, striker plate, and skinner hanger using 2 screws. *Apply Loctite 242 to screws then torque to 30-35 lb-in.*
9. Connect switch wires by carefully connecting corresponding wire terminals inside motor housing. The connections should be sealed with shrink tube.
10. Reinstall front cover to motor assembly using 4 screws and washers. *Apply Loctite 242 to screws then torque to 30-35 lb-in.*

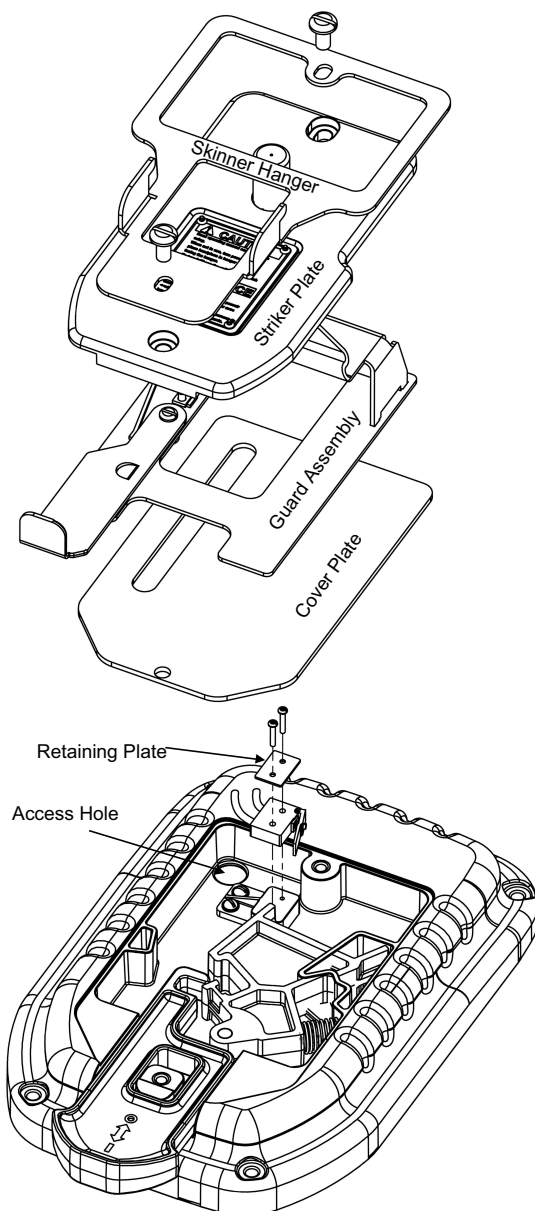

SHRINK TUBE
1/2" ID X 1" LONG

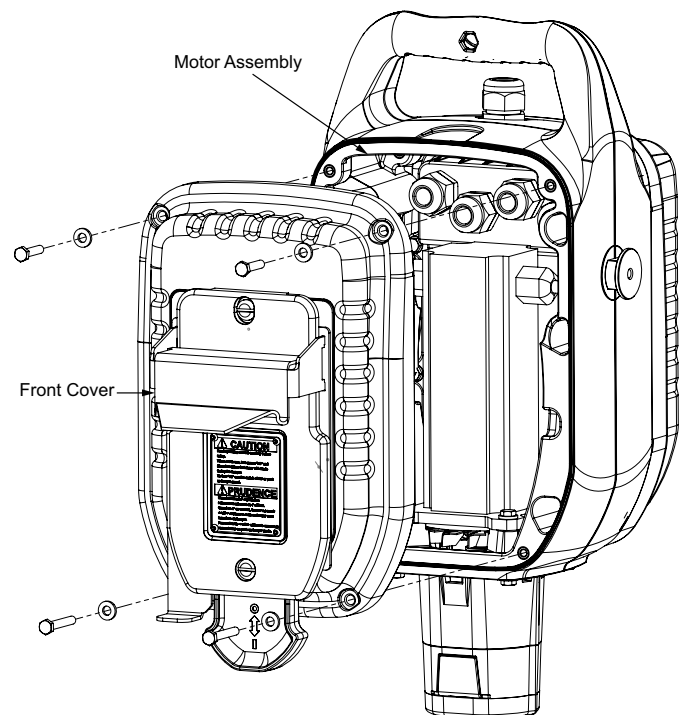

FUSE REPLACEMENT

 **WARNING**

To avoid personal injury, always disconnect the power cord before performing any adjustments, disassembly/assembly, troubleshooting or cleaning.



Always disconnect the power and remove the tool from the driveline prior to servicing.

All electrical repairs should be completed by a qualified electrician or approved service provider.

1. Disassemble unit. *Refer to Section 5, Disassembly.*
2. You can now access fuses and replace if required. Fuses are located in the two black housings on controller and can be removed by unscrewing center cap. *Refer to Section 7, Whizard Quantum[®] Controller Assembly to order fuses.*

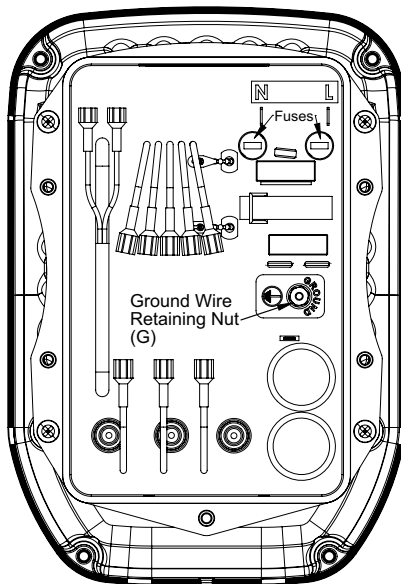

**Reassembly is the reversal of these directions.*

FAULT DETECTION AND CORRECTION

PROBLEM	PROBABLE CAUSE	REMEDY
Switch ON, Motor Will Not Start	No Input Power	Check Power Plug. Check Input Power.
	Power Switch Failure	Check Power at Switch Wires. Replace Switch.
	Motor Failure	Check Connections Inside Control Panel Assembly. Replace Motor.
	Controller Failure	Replace Controller.
	Fuse Blown	Check Fuses.
	Blade Locked Up	Make Certain Blade Freely Rotates.
Motor Stops While Operating	Motor Failure	Replace Motor.
	Brown Out	Cycle Switch Lever.
	Excessive Torque	Cycle Switch Lever.

Section 6

Cleaning

CONTENTS OF THIS SECTION

Cleaning 6-2



To avoid personal injury, always disconnect the power cord before performing any adjustments, disassembly / assembly, trouble shooting or cleaning.



Always disconnect the power and remove the tool from the driveline prior to servicing.



The recommended cleaning solution for the Whizard Quantum™ Drive Unit is eXtra© Heavy Duty Cleaner.



eXtra© Heavy Duty Cleaner, (PN: 184332), is a concentrated cleaner and degreaser for food processing equipment. Contact Bettcher Industries, Inc. for details.



Do not submerge or directly spray drive unit. Damage could occur and may void the warranty. Clean with damp cloth or sponge only. Dry after cleaning.

CLEANING

The Whizard Quantum[®] Drive is of wash down construction and the following cleaning procedure is recommended: Wipe the outside of the motor and controller housing with mild detergent or cleaner with a pH less than 9.

The hanger assembly should be disassembled and cleaned periodically. Remove the two screws that hold the striker plate in place and remove the striker plate, peg, guard, cover plate, actuator, spring and slider. Wash all the parts with mild detergent or cleaner with a pH less than 9. Inspect the inside of the hanger housing and clean in the same manner, if needed. Dry all parts and reassemble.

For best results, clean with Bettcher[®] eXtra[©] Heavy Duty Cleaner. eXtra[©] Heavy Duty Cleaner is a concentrated cleaner and degreaser for food processing equipment. Dilute according to the directions on the container.

Section 7

Service Parts

CONTENTS OF THIS SECTION

Whizard Quantum [®] Motor Assembly	7-2
Whizard Quantum [®] Drive Assembly	7-4
Whizard Quantum [®] Disconnect Assembly	7-6
Whizard Quantum [®] Switch Assembly	7-8
Whizard Quantum [®] Controller Assembly	7-10
Also Available	7-12



The manufacturer assumes no liability for any unauthorized changes in operating procedures or for unauthorized changes or modifications made to the design of the machine or any factory-installed safety equipment, whether these changes are made by the owner of this equipment, by his employees, or by service providers not previously approved by Bettcher Industries, Inc.

Use only replacement parts manufactured by Bettcher Industries, Inc. Use of substitute parts will void the warranty and may cause injury to operators and damage to equipment.

The use of parts other than those listed in the parts list for the specific model may cause blade lock-up, resulting in an unsafe operating condition.

WHIZARD QUANTUM[®] MOTOR ASSEMBLY

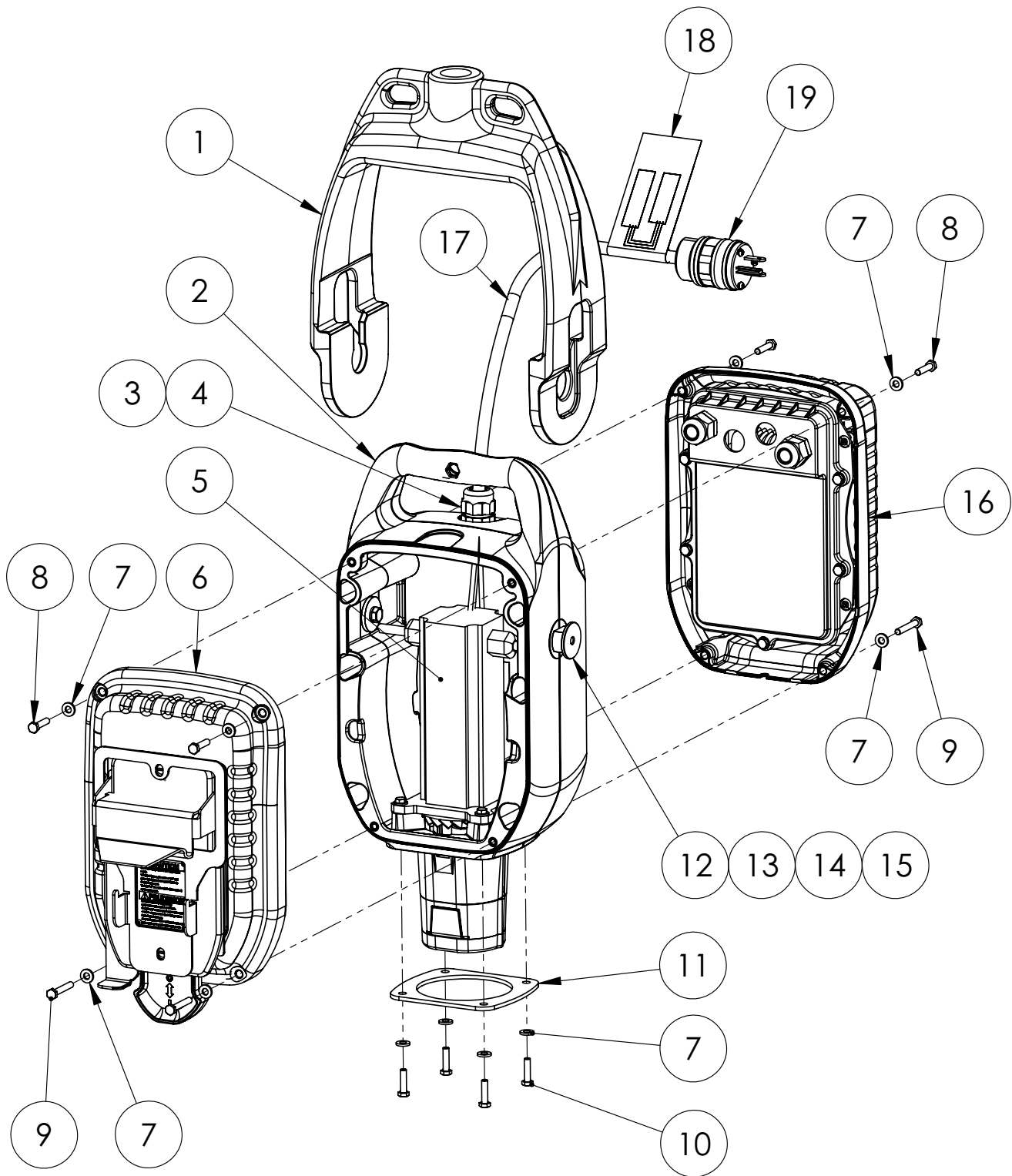

WHIZARD QUANTUM[®] MOTOR ASSEMBLY (CONTINUED)

ITEM	DESCRIPTION	PART NUMBER	QTY
1	SUPPORT YOKE	189023	1
2	FRAME ASSEMBLY	189006	1
3	STRAIN RELIEF	123002	1
4	LOCK NUT	189037	1
5	DRIVE ASSEMBLY	REF	1
6	SWITCH ASSEMBLY	REF	1
7	WASHER	123528	12
8	SCREW 7/8"	122206	4
9	SCREW 1-1/4"	123288	4
10	SCREW 3/4"	120766	4
11	SUPPORT PLATE	189024	1
12	PIVOT	189025	2
13	LARGE WASHER	189026	2
14	LOCK WASHER	120220	2
15	HEX SCREW 3/4"	121408	2
16a	CONTROLLER ASSEMBLY, WHIZARD QUANTUM DRIVE "SKINNER", (115V)	REF	1
16b	CONTROLLER ASSEMBLY, WHIZARD QUANTUM DRIVE "SKINNER", (230V)	REF	---
17a	POWER CORD (115V)	189040	1
17b	POWER CORD (230V)	103027	---
18	WIRE TAG	189039	1
19	PLUG (115V ONLY)	103413	1

WHIZARD QUANTUM[®] DRIVE ASSEMBLY

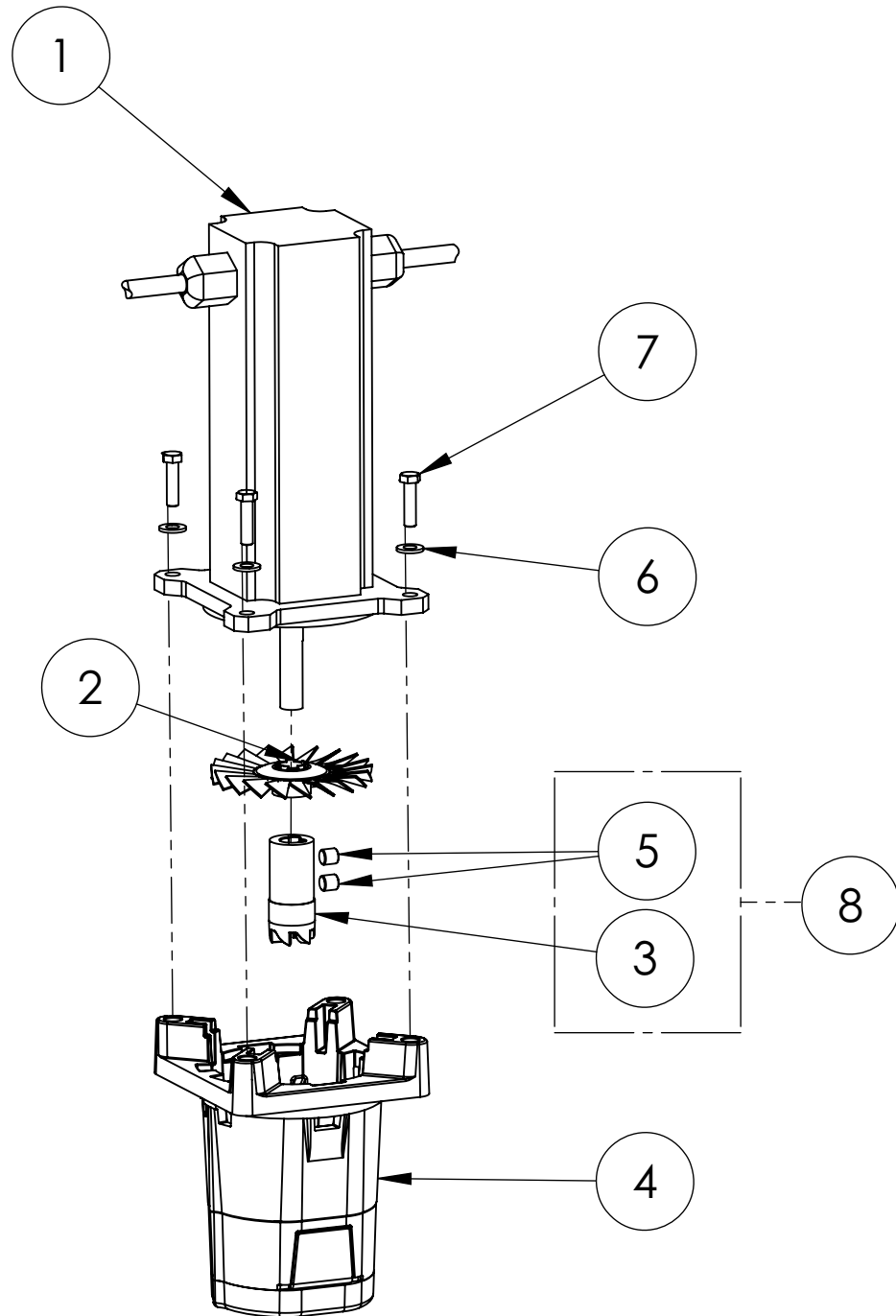

WHIZARD QUANTUM[®] DRIVE ASSEMBLY (CONTINUED)

ITEM	DESCRIPTION	PART NUMBER	QTY
1	MOTOR	189034	1
2	FAN & SET SCREW	189036	1
3	DRIVE ADAPTER	103748	1
4	DISCONNECT ASSEMBLY	189053	1
5	SET SCREW	123117	2
6	WASHER	123528	4
7	SCREW	120766	4
8	MOTOR DRIVER KIT	103881	1

WHIZARD QUANTUM[®] DISCONNECT ASSEMBLY

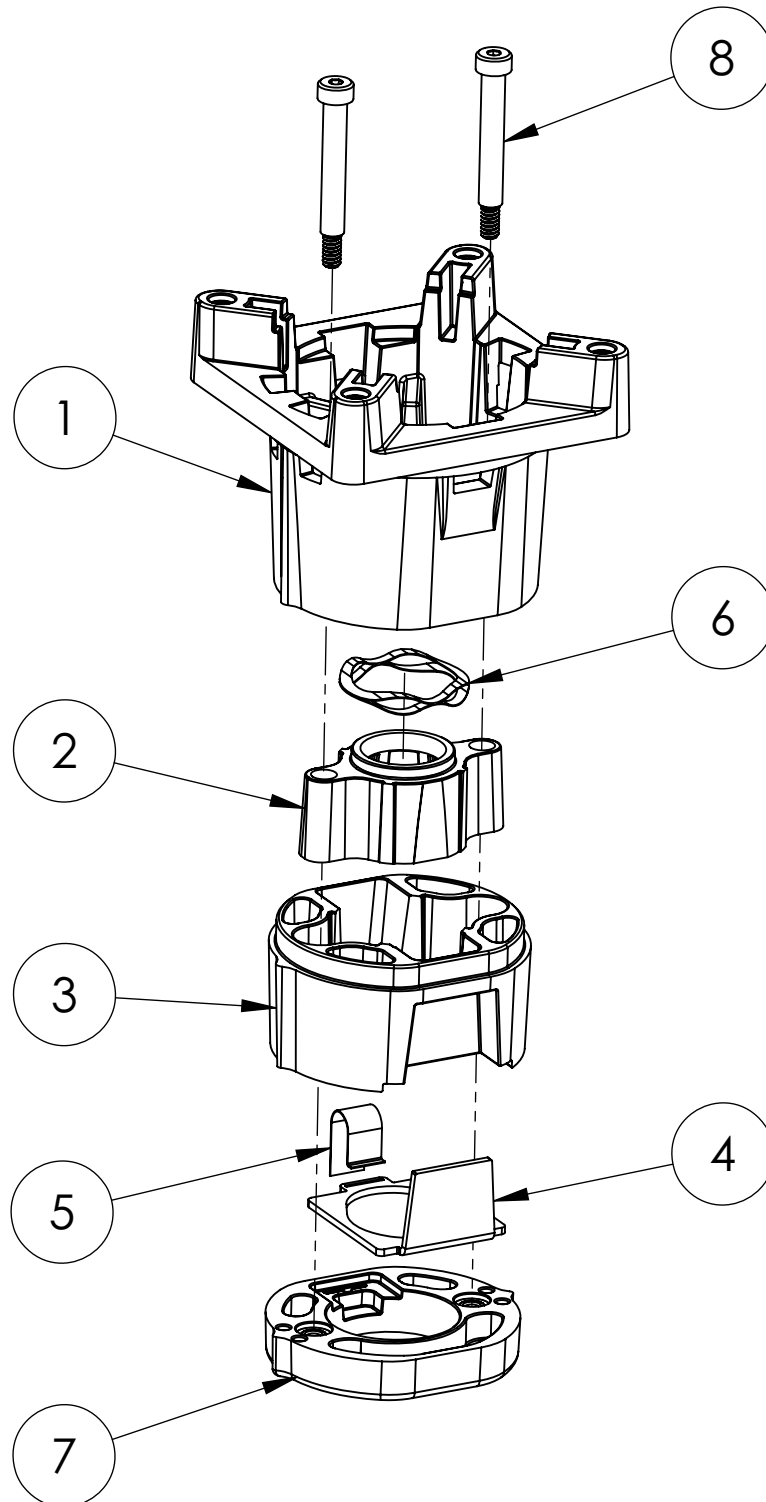

WHIZARD QUANTUM[®] DISCONNECT ASSEMBLY (CONTINUED)

ITEM	DESCRIPTION	PART NUMBER	QTY
1	UPPER HOUSING	189054	1
2	TAPERED COLLAR	189082	1
3	LOWER HOUSING	100638	1
4	LATCH	189057	1
5	LATCH SPRING	189058	1
6	WAVE SPRING	189063	1
7	BOTTOM CAP	189076	1
8	SCREW	189061	2

WHIZARD QUANTUM[®] SWITCH ASSEMBLY

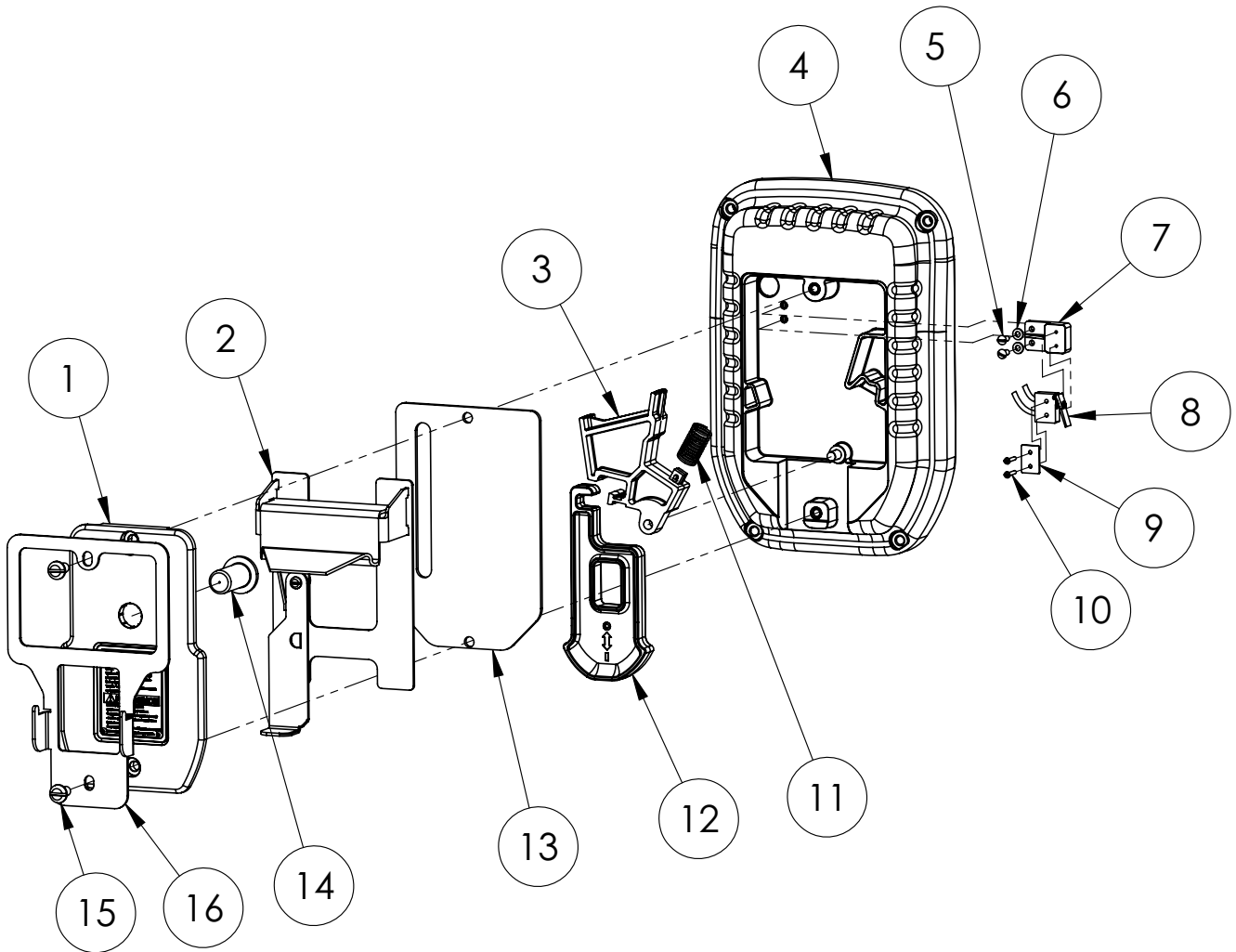

WHIZARD QUANTUM[®] SWITCH ASSEMBLY (CONTINUED)

ITEM	DESCRIPTION	PART NUMBER	QTY
1	STRIKER PLATE	189010	1
2	GUARD ASSEMBLY	189028	1
3	ACTUATOR	163550	1
4	FRONT COVER, YELLOW, WHIZARD QUANTUM DRIVE	189007	1
5	SCREW 5/16"	120144	2
6	LOCK WASHER	120233	2
7	SWITCH MOUNT	163669	1
8	SWITCH KIT (INCLUDES TERMINALS)	189038	1
8a	TERMINAL (NOT SHOWN)	124967	2
9	RETAINING PLATE	183134	1
10	SCREW 1/2"	123260	2
11	SPRING	121622	1
12	SWITCH LEVER	189008	1
13	COVER PLATE	189027	1
14	PEG	163418	1
15	SCREW 1"	123255	2
16	SKINNER HANGER	108283	1

WHIZARD QUANTUM[®] CONTROLLER ASSEMBLY

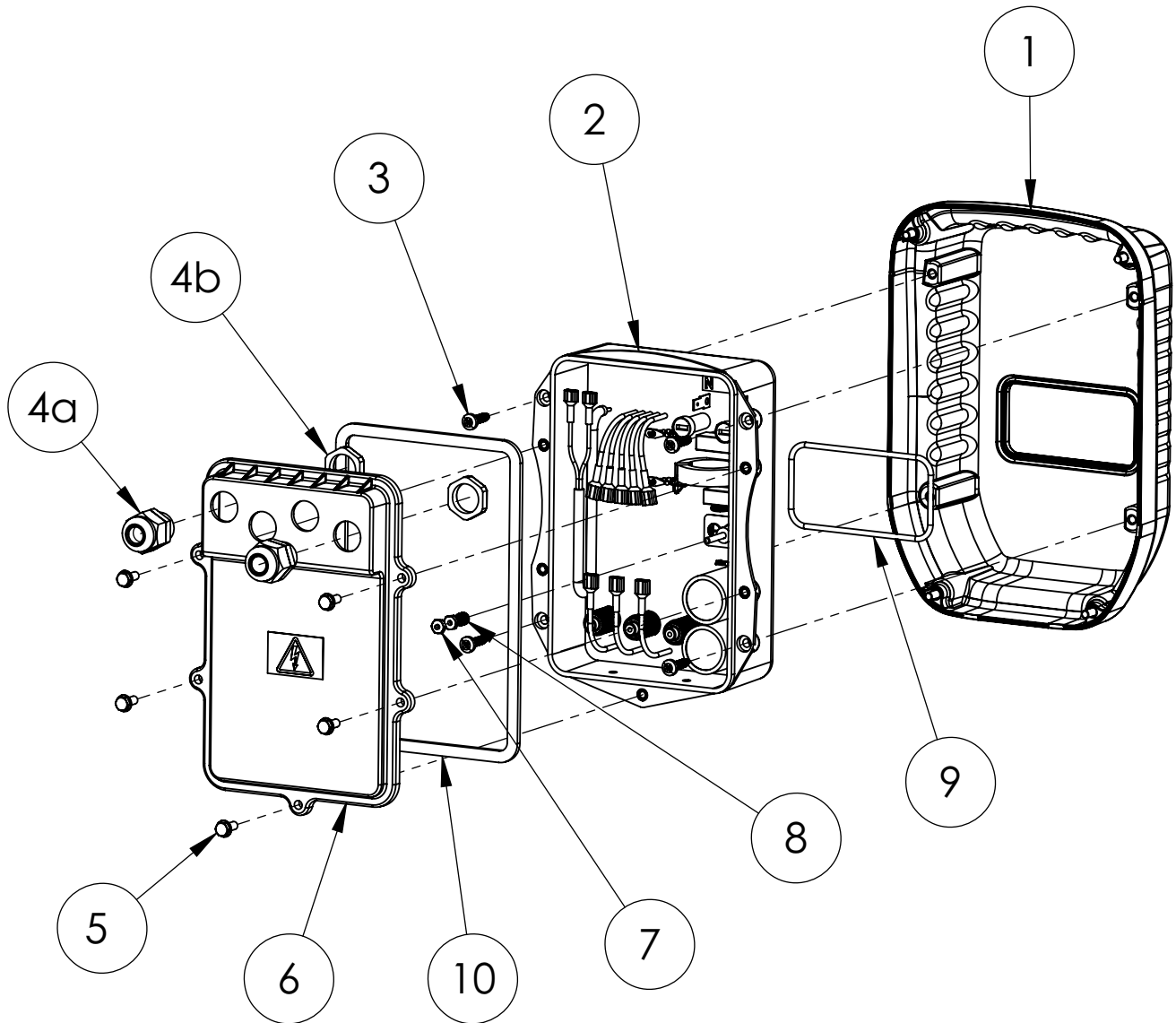

WHIZARD QUANTUM[®] CONTROLLER ASSEMBLY (CONTINUED)

ITEM	DESCRIPTION	PART NUMBER	QTY
1	REAR COVER, YELLOW, WHIZARD QUANTUM DRIVE	189012	1
2a	CONTROLLER, 115V, WHIZARD QUANTUM DRIVE "SKINNER"	108421	1
2b	CONTROLLER, 230V, WHIZARD QUANTUM DRIVE "SKINNER"	108422	1
3	SELF TAPPING SCREW	189011	4
4a	STRAIN RELIEF PG11	123002	4
4b	LOCK NUT (SUPPLIED WITH 123002)	REF	4
5	WASHER HEAD SCREW	123258	5
6	CONTROLLER COVER	189014	1
7	NUT	120336	2
8	LOCK WASHER	120240	5
9	SEAL	189050	1
10	COVER GASKET	189086	1
11	FUSE (NOT SHOWN)	101715	2

ALSO AVAILABLE

ITEM	DESCRIPTION	PART NUMBER
1	EXTRA [®] HEAVY DUTY CLEANER (1 CASE)	184331
2	EXTRA [®] HEAVY DUTY CLEANER (1 GALLON)	184332
3	DRIVER ADAPTER SET GAUGE	103149

Section 8

Contact and Document Information

CONTENTS OF THIS SECTION

Contact Address and Phone	8-2
Document Identification	8-2

CONTACT ADDRESS AND PHONE

For additional information, technical support and spare parts, contact your Regional Manager, Distributor, or Bettcher Representative:

Bettcher Industries, Inc.
6801 State Route 60
Birmingham, OH 44889
USA
Tel: +1 440/965-4422
Fax: +1 440/328-4535

BETTCHER GmbH
Pilatusstrasse 4
CH-6036 Dierikon
SWITZERLAND
Tel: +011-49-32-221-850-896
Fax: +011-41-41-348-0229

Bettcher do Brasil Comércio de Máquinas Ltda.
Av. Fagundes Filho, 145 Cj 101/102 - São Judas
São Paulo - SP
CEP 04304-010 - BRASIL
Tel: +55 11 4083 2516
Fax: +55 11 4083 2515

DOCUMENT IDENTIFICATION

Copies of this Operation Instruction may be ordered by quoting the Document ID as listed below:

Document ID:	Manual # 109211
Document Description:	Operating Instructions and Spare Parts List for the Whizard Quantum [®] Drive
Issued:	Date: December 13, 2019

Operating Instructions for Whizard Quantum[®] Drive may be requested by quoting the model designation of the tool as shown on the identification plate on the Whizard Quantum[®] Drive.

SOFTWARE AND DUPLICATION

For more information, contact your local Representative or:

Bettcher Industries, Inc.
Administrative Assistant/Engineering Department
PO Box 336
Vermilion, Ohio 44089
USA